

Industrial Motors
Commercial &
Appliance Motors
Automation
Digital &
Systems
Energy
Transmission &
Distribution
Coatings

MPW – Motor Protective Circuit Breakers

The **complete
solution** for motor
switching and
protection



Driving efficiency and sustainability



SUMMARY

Introduction

04

Main characteristics

06

MPW12 motor protective circuit breaker

12

MPW18 motor protective circuit breaker

14

MPW40 motor protective circuit breaker

16

MPW40t motor protective circuit breaker

18

MPW80 motor protective circuit breaker

19

MPW100 motor protective circuit breaker

20

Accessories

21

Technical data

27

Mounting configurations

32

DC operation

32

Diagrams

33

Breaking capacity (IEC 60947-2)

34

Breaking capacity (IEC 60947-2) limiter function

35

Characteristic curves

36

Typical circuits

39

Dimensions (mm)

40

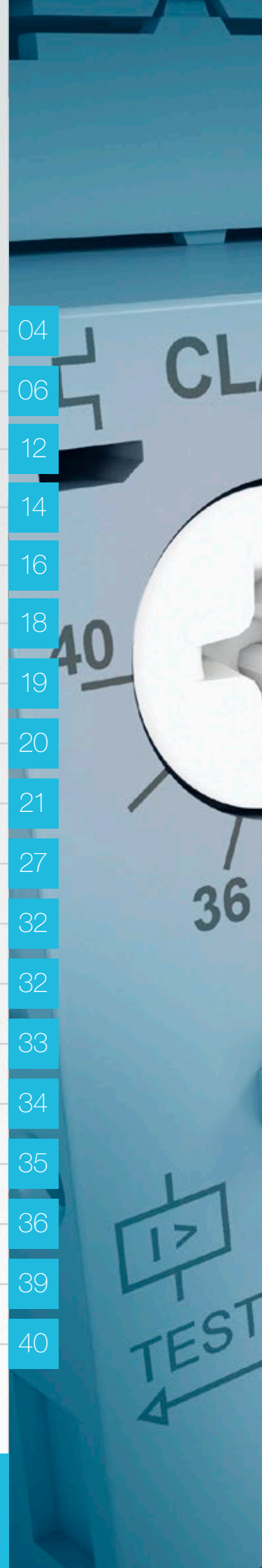

CLASS 10



32

TRIP

520 A

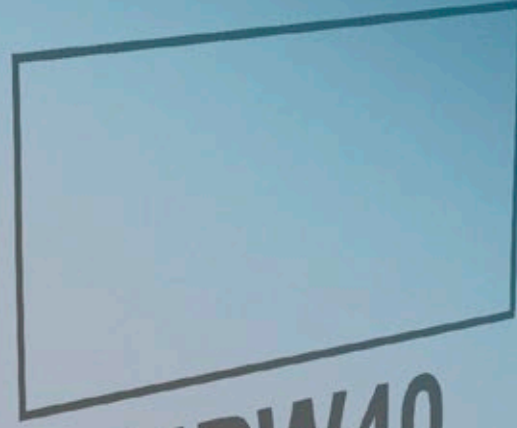

MPW40

V1A

L
ON



CLASS 10



40

36

TRIP



520 A

OFF

The complete solution for motor switching and protection



Developed according to IEC 60947 and UL 508, the MPW line of motor protective circuit breakers provides superior performance and high short-circuit interrupting capacity for your applications.

High short circuit breaking capacity (@380 V)

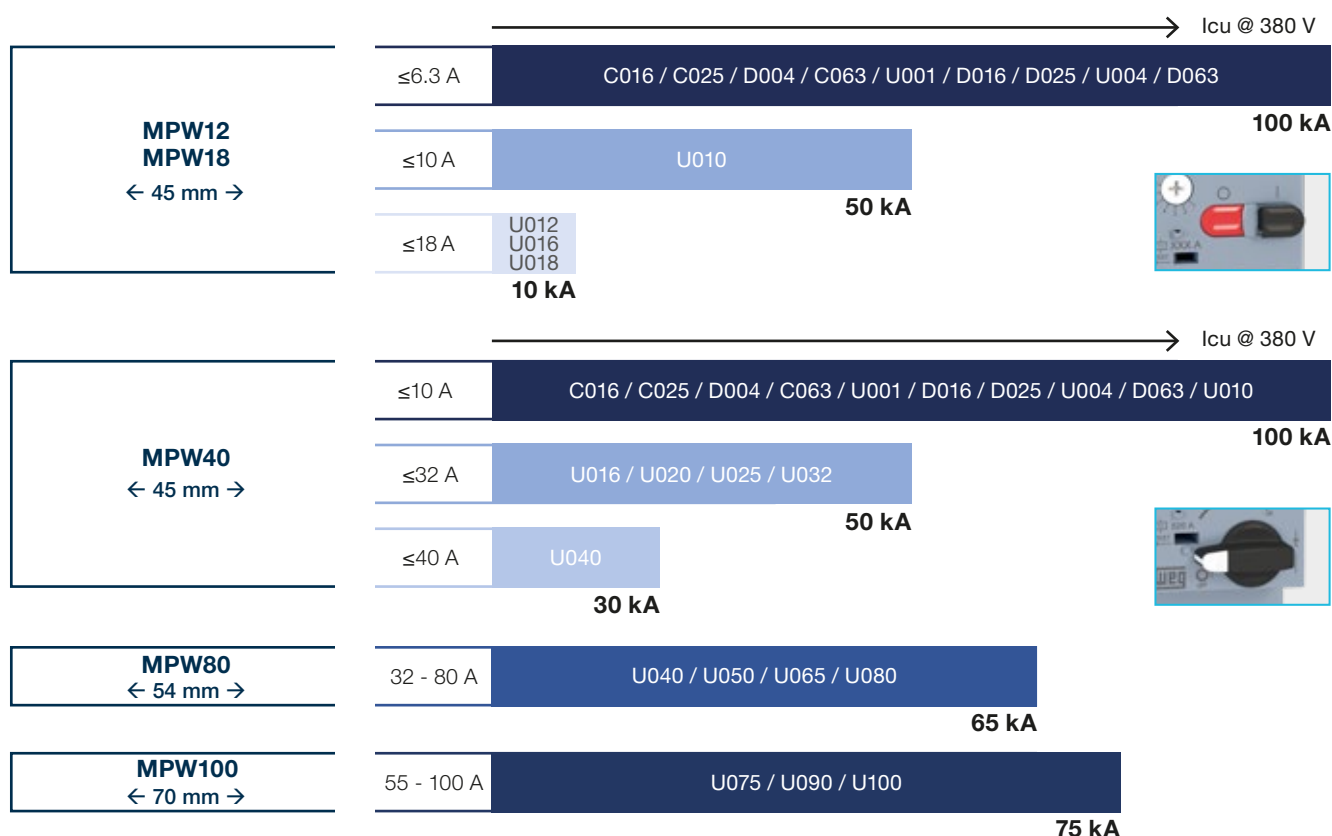



The MPW motor protective circuit breakers perform the switching and protect against overloads and short circuits, available in versions with magnetic triggers of 13 and 19 times the maximum rated current.



High durability:
up to 100,000
operation cycles



Versions with pushbuttons or
rotary knob, screw and spring
terminals

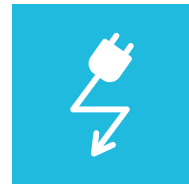

Sensitive to phase
loss according to
IEC 60947-4-1



Wide range of
interchangeable
accessories



Compact combined starter sets
(direct online, reversing and delta-star)
with the CWB9...80 contactors and
CWC07...25 miniature contactors



Function of molded-case circuit
breaker/fuse and overload relay
in a single product

Main certifications



Mexico



Marine



European
Union



United Kingdom



Russia



Argentina



Canada and USA

Main characteristics

Three functions in a single product

Its main function is the protection against short circuits and overloads in electric motor applications. In addition, they allow switching operations (15 operations/hour) directly with their handle or buttons.

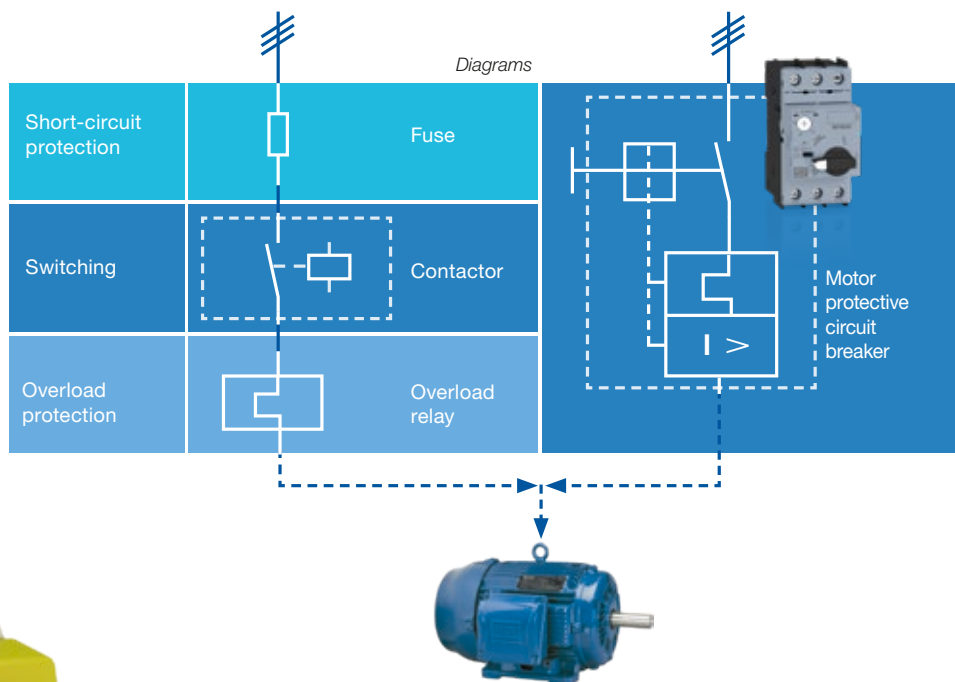

Handles for thermogram

The models of MRX handles coupled to the circuit breaker allow to open panels even with the handle in the ON position. This kind of function is commonly used on electrical panels where a thermographic analysis is necessary in preventive maintenance events. As default, this function comes disabled from the factory.

Position and state indication

Front identification of the operating status of the circuit breaker by means of its rotary handle (MPW40...100) or key (MPW18). On the motor protective circuit breakers with rotary drive, it is possible to indicate the TRIP with their handle, and their marking indicates the position of the electrical circuit switching devices.

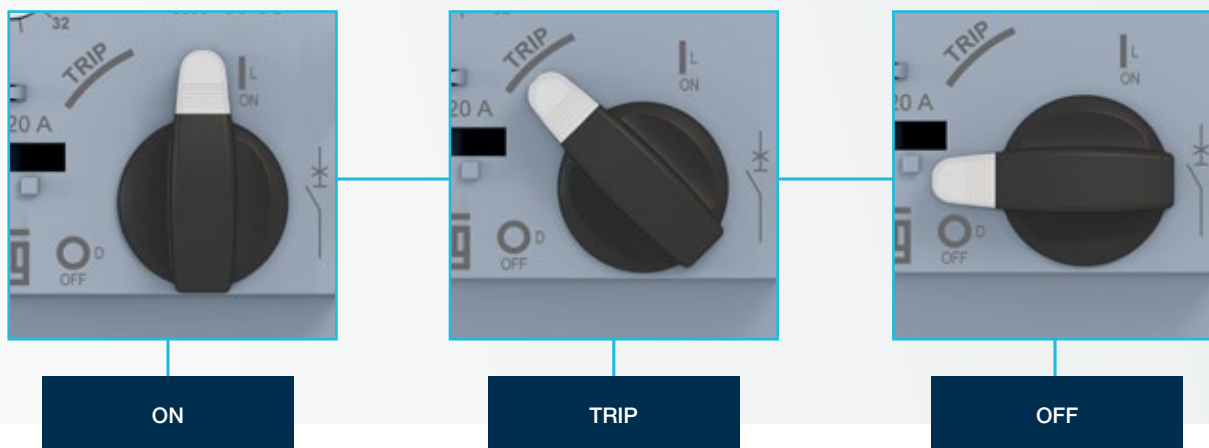

Main characteristics

Lock out, isolation and main switch

All the MPW circuit breakers can be locked by means of seals or padlocks installed on the handle or front button, ensuring greater safety in stoppages for maintenance of panels and electric motors. In addition to this function, the circuit breakers comply with the isolation conditions of IEC 60947-3 and IEC 60947-2, that is, they may be used as an isolation device of electrical parts of a panel. They can also be used as main switches and emergency stop according to IEC 60204-1.



Ø 2...4 mm

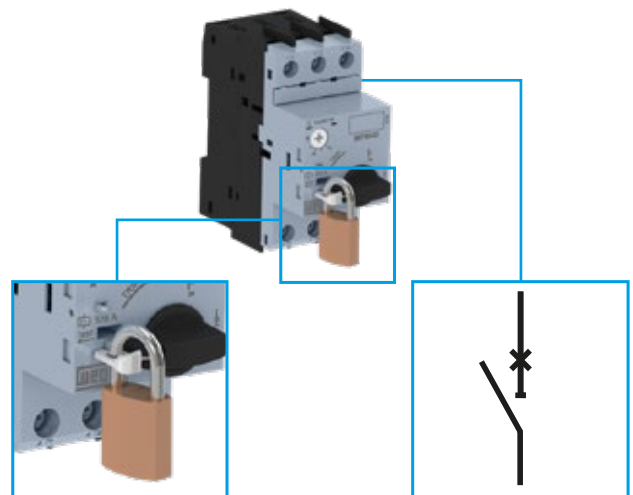

IEC 60204-1

Connectors and busbars

Connection busbars (easy connection) developed to save time and avoid assembly errors by panel installers and original equipment manufacturers (OEMs).

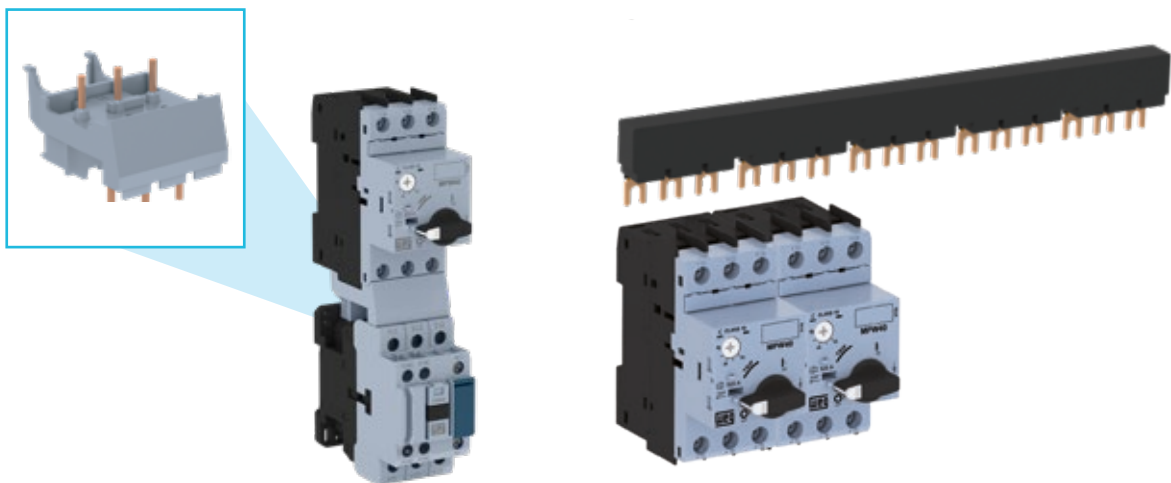

TSB block for trip indication

The TSB accessory installed on the circuit breakers allow to signal the trip occurred by means of auxiliary contacts or mechanical indicators on this accessory.

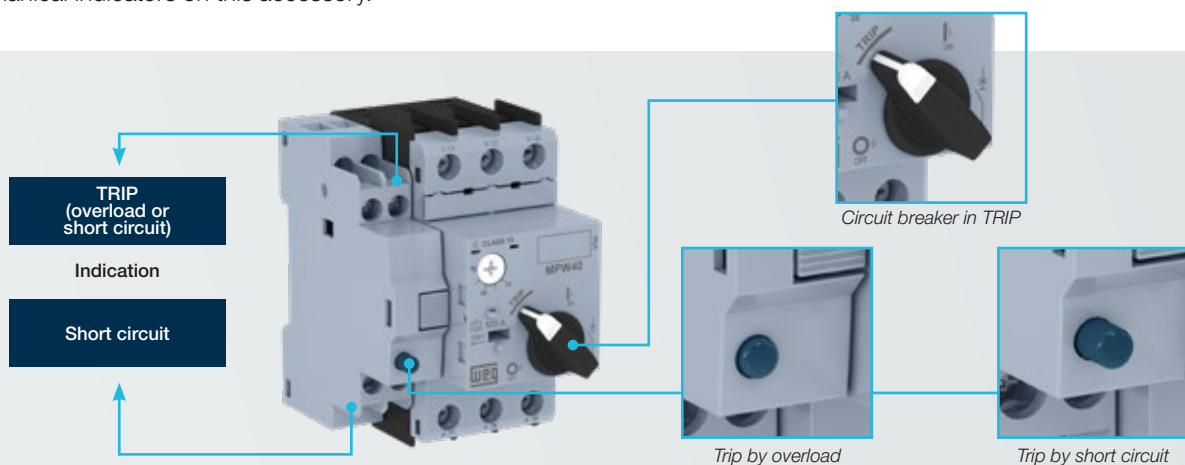

Note: using the TSB accessory, it is possible to use only one of the auxiliary contacts, the front (ACBF) or side (ACBS) contact.

Main characteristics

Handles for external drive

Additional handles installed on the MPW circuit breakers allow external drive of the circuit breakers on panels, ensuring safe operations and full isolation of the live parts from the users. Versions available with degree of protection IP55, IP65 and NEMA4X (UL), in yellow/red and grey/black.

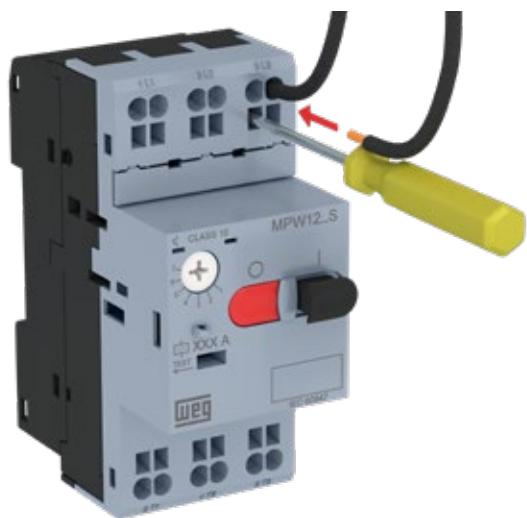
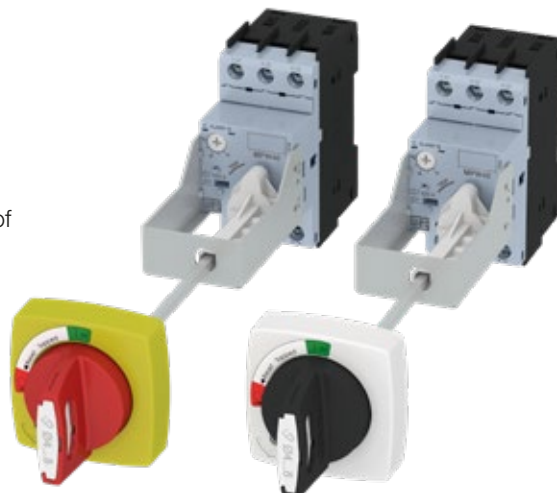

Faster and securer connections

The cage clamp connections of the MPW12 motor protective circuit breakers provide faster installation of power cables and accessories. With a screwdriver suitable for the fitting, it is possible to make the connections in a shorter time in comparison to screw terminals. Due to special springs on the connection terminals, retightening is not necessary, because the connection system ensures constant pressure on the cables.

Protection of the current setting dial

It allows to lock the current setting dial on the thermomagnetic circuit breakers. By using a seal together with this accessory, it is possible to ensure the reliability of the current setting on the circuit breakers installed in the field on electrical panels and machines. Supplied as accessory on the MPW12...80 circuit breakers and as standard on the MPW100 circuit breakers.

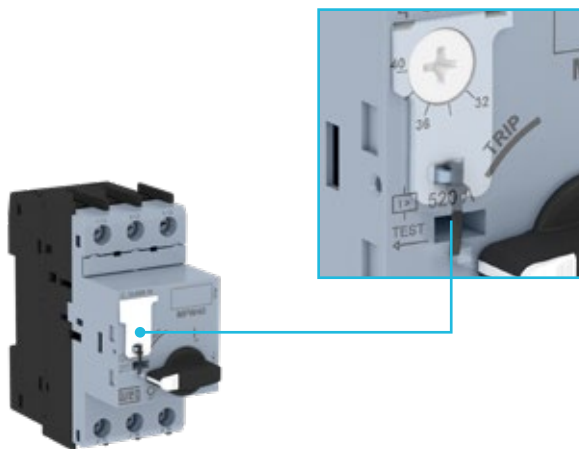

Insulated enclosures

In applications with a reduced number of starts (15 starts/hour), it is possible to use surface-mount boxes IP41/IP66 for MPW12 and MPW18, and IP55 for boxes with MPW40, with direct drive on the circuit breakers very close to the electric motor. The rotary handle of the surface-mount boxes enables the lock out with up to three padlocks. On the surface-mount boxes for models MPW12 and MPW18, versions with keyed emergency pushbuttons enable the lock out of their operation. ACBS, ACBF, URMP/SRMP are accessories that can be installed within the box.

Main characteristics

Interchangeable accessories

All the main accessories are interchangeable among the models MPW18...80, allowing the optimization of items and greater flexibility of their applications. Example: the front contact block can be installed on up to three different models.

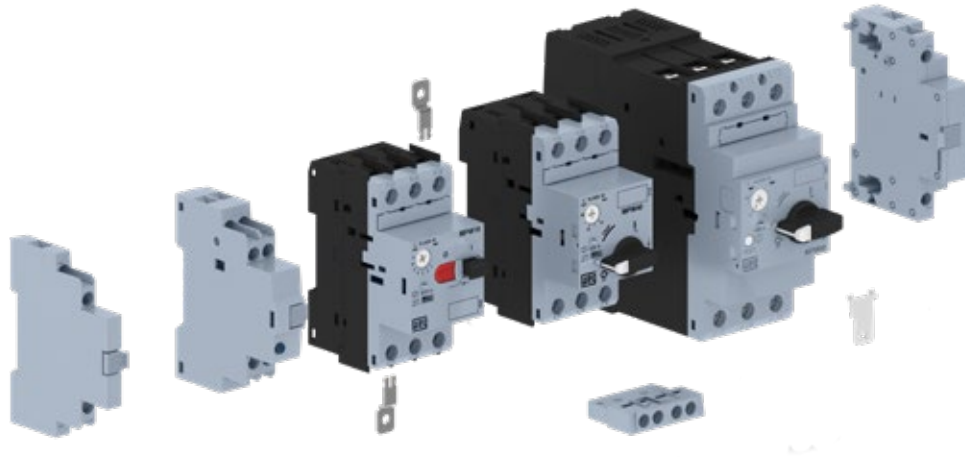

Easy assembly

Assembly and disassembly of the side contact blocks, trip indication blocks and undervoltage coils without tools, just by means of fittings on the side of the circuit breaker.

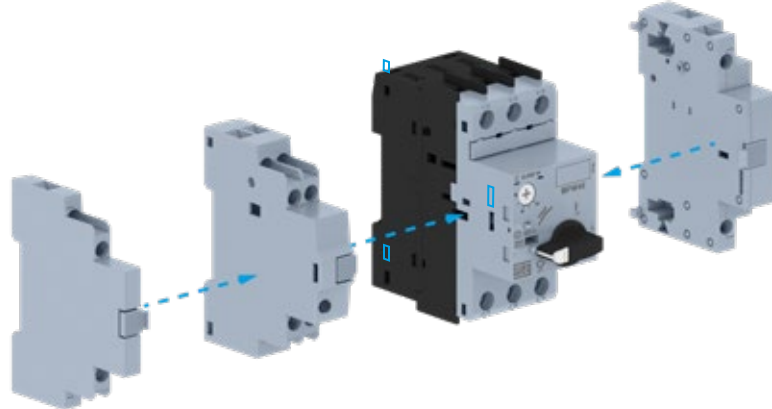

Safety in installation

All the motor protective circuit breakers have degree of **protection IP20** on the front to prevent inadvertent contacts with the live parts without requiring additional accessories.

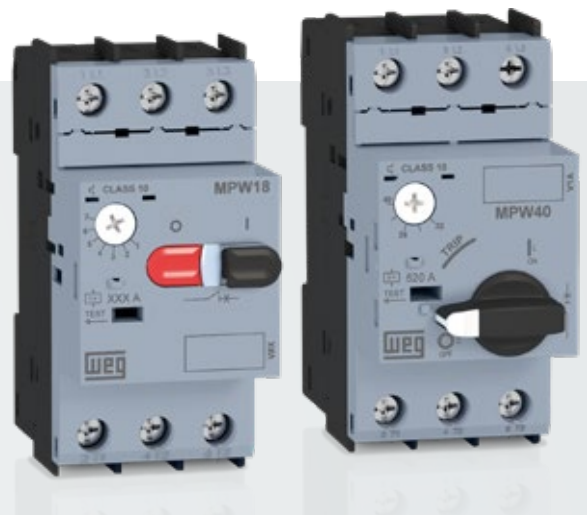



Benefits of using **motor protective circuit breakers** on electrical panels



Inventory optimization

Conventional panels that use fuses for protection against short circuit require replacement after they trip. The spare fuses for panels with such conception require physical space in the maintenance area and inventory item control. Using motor protective circuit breakers, that is not necessary, because they allow reset even after a trip by short circuit.



Shorter downtime

Stoppages because of an overload trip may be common in some applications with this kind of characteristic in case of some anomaly. In some operations, the downtime of machines may represent huge losses and damages to industrial processes. The use of motor-protective circuit breakers provides shorter reset time of a machine/equipment, because the circuit breaker allows its reset even after a trip by short circuit.



Design simplification

In order to size fuses on electrical panels for motor start, it is necessary to pay attention to the time of each start: direct online (5s), delta-star (10s), reduced voltage (15s). Also, in the sizing of components to protect delta-star starters using fuses, we often find applications that require six fuses and thus additional wiring. Using motor protective circuit breakers, your project is simplified down to a single component.



Cable connection

The circuit breakers allow direct connection of cables to them without the need for terminals at the end of the connection cables.



Cost reduction

The designs with motor protective circuit breakers are smaller than those with protection by molded-case circuit breakers or fuses. They allow the assembly on DIN rail 35 mm, avoiding unnecessary expenses with fastening by screws. Over 50% of reduction of assembly space.

Conventional panels with:

Molded-case circuit breakers

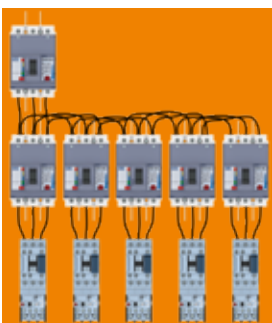

Fuses

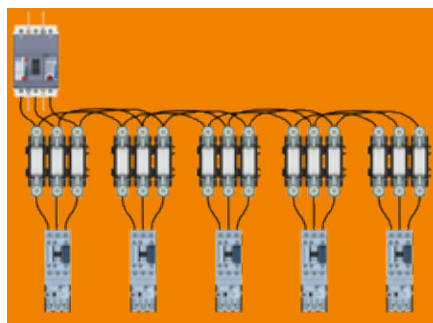

Compact panel with:

Motor protective circuit breakers

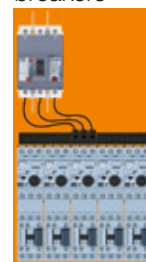

Environmentally friendly

Manufactured with materials of low impact on the environment and according to the RoHS international requirements.



Issued by the Parliament and by the European Council, the RoHS restricts the use of hazardous substances on electronic products traded in the countries members of the EU, **prohibiting the ingress of new products on the market** in case they contain lead, cadmium, hexavalent chromium, mercury, polybrominated biphenyl (PBB) and polybrominated diphenyl ethers (PBDE).
The MPW line complies with the RoHS requirements.



MPW12 motor protective circuit breaker

Overview

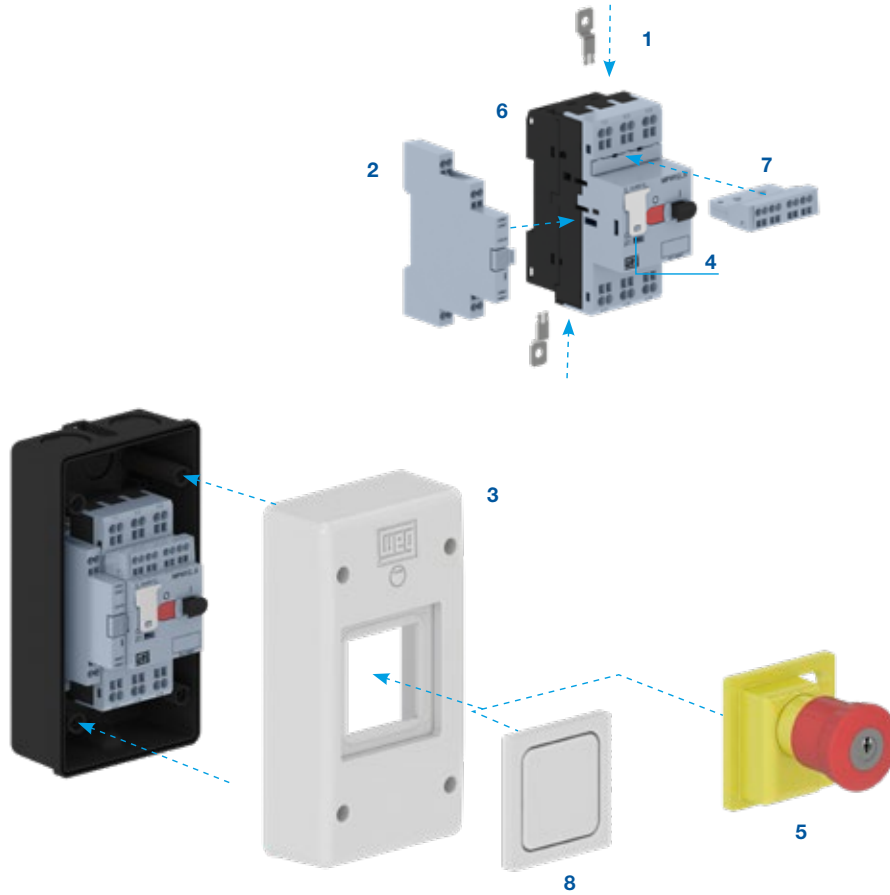

- 1 - Push-in-lugs PLMP
- 2 - Side-mounted auxiliary contact block ACBS_S (spring terminal)
- 3 - Insulated enclosures
- 4 - Scale cover SCMP

- 5 - Emergency pushbutton for insulated enclosure
- 6 - MPW12 motor protective circuit breaker (spring terminal)
- 7 - Front mounted auxiliary contact block ACBF_S (spring terminal)
- 8 - MPE41 cover for PE66



MPW12 motor protective circuit breaker

Selection table

MPW12 motor protective circuit breaker up to 12 A - thermomagnetic or magnetic only

- Spring terminal
- With overload and short-circuit protection
- Fixed short-circuit release 13 times the maximum circuit breaker rated current
- Phase-failure sensitivity according to IEC 60947-4-1
- Environment temperature compensation
- For use as main switch (IEC 60947-2)
- Self-protected against short circuit up to 6.3 A at 500 V_{AC}
- Thermomagnetic motor protective circuit breaker with overload protection (class 10)



MPW12 motor protective circuit breaker - thermomagnetic - overload and short-circuit protection

Reference values for selecting protection of three-phase electric motors 60 Hz - 4 poles ¹⁾			Rated current I _n (A)	Overload release setting I _n (A)	Instantaneous magnetic trip 13x I _n I _m (A)	Spring terminal		Weight kg
220-240 V cv / kW	380-415 V cv / kW	440-480 V cv / kW				Reference	Code	
-	-	-	0.16	0.1...0.16	2.08	MPW12-3-C016S	12500989	0.28
-	-	-	0.25	0.16...0.25	3.25	MPW12-3-C025S	12500990	
-	-	0.16 / 0.12	0.4	0.25...0.4	5.2	MPW12-3-D004S	12500992	
-	0.16 / 0.12	0.25 / 0.18	0.63	0.4...0.63	8.2	MPW12-3-C063S	12500991	
0.16 / 0.12	0.33 / 0.25	0.33 / 0.25	1	0.63...1	13	MPW12-3-U001S	12500996	
0.33 / 0.25	0.5 / 0.37	1 / 0.75	1.6	1...1.6	20.8	MPW12-3-D016S	12500993	
0.5 / 0.37	1 / 0.75	1.5 / 1.1	2.5	1.6...2.5	32.5	MPW12-3-D025S	12500994	
1 / 0.75	2 / 1.5	2 / 1.5	4	2.5...4	52	MPW12-3-U004S	12500997	
1.5 / 1.1	3 / 2.2	4 / 3	6.3	4...6.3	82	MPW12-3-D063S	12500995	
3 / 2.2	6 / 4.5	7.5 / 5.5	10	6.3...10	130	MPW12-3-U010S	12501028	
4 / 3	7.5 / 5.5	7.5 / 5.5	12	8...12	156	MPW12-3-U012S	12501029	

MPW12i motor protective circuit breaker - magnetic - short circuit protection²⁾

Reference values for selecting protection of three-phase electric motors 60 Hz - 4 poles ¹⁾			Rated current I _n (A)	Instantaneous magnetic trip 13x I _n I _m (A)	Spring terminal		Weight kg
220-240 V cv / kW	380-415 V cv / kW	440-480 V cv / kW			Reference	Code	
-	-	-	0.16	2.08	MPW12i-3-C016S	12501032	0.28
-	-	-	0.25	3.25	MPW12i-3-C025S	12501033	
-	-	0.16 / 0.12	0.4	5.2	MPW12i-3-D004S	12501035	
-	0.16 / 0.12	0.25 / 0.18	0.63	8.2	MPW12i-3-C063S	12501034	
0.16 / 0.12	0.33 / 0.25	0.33 / 0.25	1	13	MPW12i-3-U001S	12501059	
0.33 / 0.25	0.5 / 0.37	1 / 0.75	1.6	20.8	MPW12i-3-D016S	12501036	
0.5 / 0.37	1 / 0.75	1.5 / 1.1	2.5	32.5	MPW12i-3-D025S	12501037	
1 / 0.75	2 / 1.5	2 / 1.5	4	52	MPW12i-3-U004S	12501060	
1.5 / 1.1	3 / 2.2	4 / 3	6.3	82	MPW12i-3-D063S	12501058	
3 / 2.2	6 / 4.5	7.5 / 5.5	10	130	MPW12i-3-U010S	12501061	
4 / 3	7.5 / 5.5	7.5 / 5.5	12	156	MPW12i-3-U012S	12501062	

Notes: 1) The values are only valid for WEG W22 motors at S1 duty and service factor equal to 1.

2) For magnetic Motor Protective Circuit Breakers (MPW12i), it is necessary to use an overload protection device class 10.

MPW18 motor protective circuit breaker

Overview

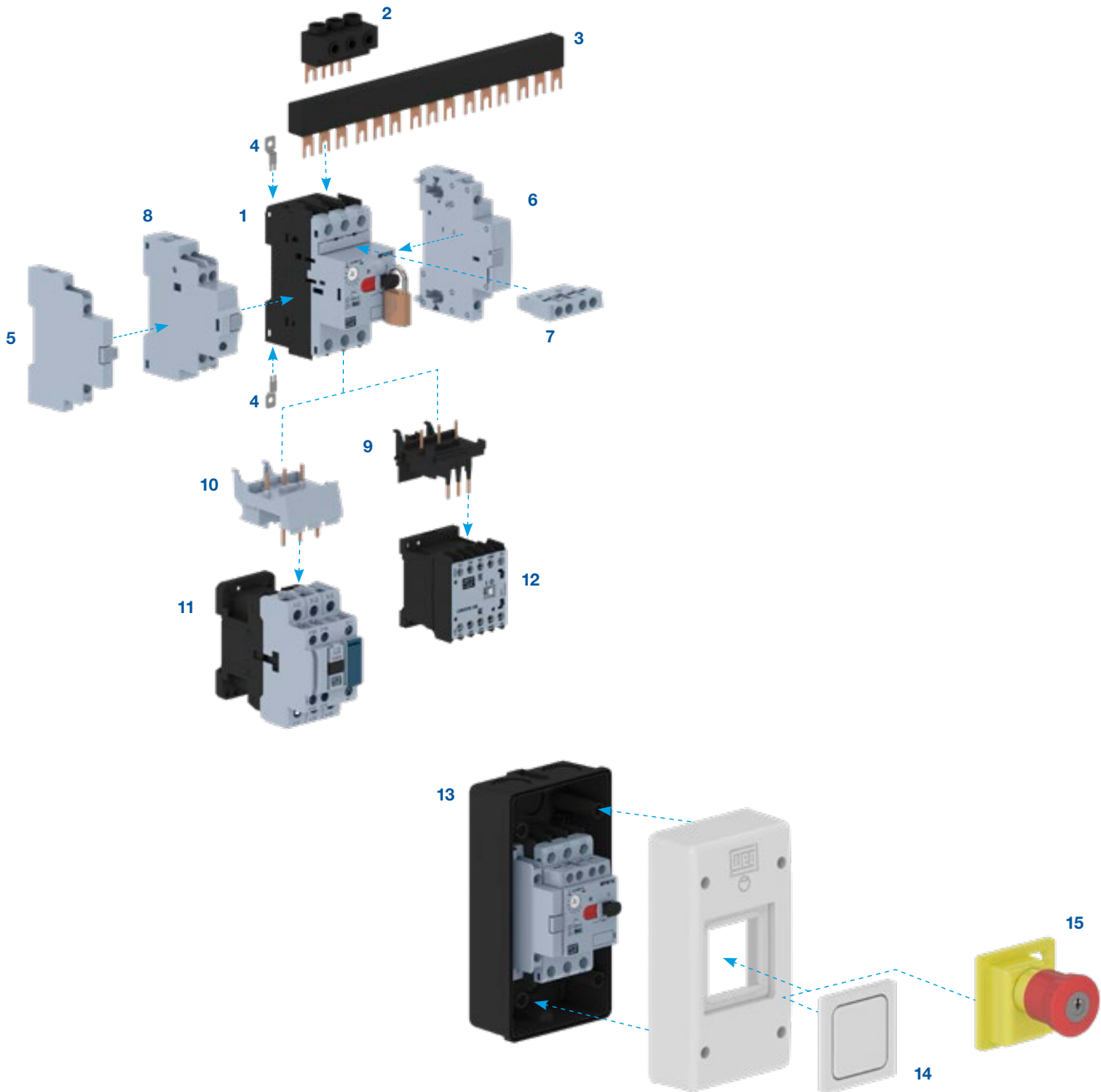

1 - MPW18 motor protective circuit breaker (screw terminal)

2 - Feeder terminal FTBBS

3 - Three-phase busbar BBS

4 - Push-in-lugs PLMP

5 - Side-mounted auxiliary contact block ACBS (screw terminal)

6 - Undervoltage release URMP or shunt release SRMP (screw terminal)

7 - Front mounted auxiliary contact block ACBF (screw terminal)

8 - Trip signaling block TSB

9 - Manual motor protector + CWC miniature contactor link module

10 - Manual motor protector + CWB contactors link module

11 - Contactors CWB9...38

12 - Miniature contactors CWC07...16

13 - Insulated enclosure

14 - Cover for PE66

15 - Emergency pushbutton for insulated enclosure

MPW18 motor protective circuit breaker

Selection table

MPW18 motor protective circuit breaker up to 18 A - thermomagnetic or magnetic only

- Allows the operation and overload and short circuit protection of electric motor
- Fixed short-circuit release 13 times the maximum circuit breaker rated current
- Phase-failure sensitivity according to IEC 60947-4-1
- Environment temperature compensation
- For use as main switch (IEC 60947-2)
- Self-protected against short circuit up to 6.3 A at 500 V_{AC}
- Thermomagnetic motor protective circuit breaker with overload protection (class 10)



MPW18 motor protective circuit breaker - thermomagnetic - overload and short-circuit protection

Reference values for selecting protection of three-phase electric motors 60 Hz - 4 poles ¹⁾			Rated current I _n (A)	Overload release setting I _n (A)	Instantaneous magnetic trip 13x I _n I _m (A)	Spring terminal		Weight kg
220-240 V cv / kW	380-415 V cv / kW	440-480 V cv / kW				Reference	Code	
-	-	-	0.16	0.1...0.16	2.08	MPW18-3-C016	12429311	0.28
-	-	-	0.25	0.16...0.25	3.25	MPW18-3-C025	12429312	
-	-	0.16 / 0.12	0.4	0.25...0.4	5.2	MPW18-3-D004	12429313	
-	0.16 / 0.12	0.25 / 0.18	0.63	0.4...0.63	8.2	MPW18-3-C063	12429315	
0.16 / 0.12	0.33 / 0.25	0.33 / 0.25	1	0.63...1	13	MPW18-3-U001	12429317	
0.33 / 0.25	0.5 / 0.37	1 / 0.75	1.6	1...1.6	20.8	MPW18-3-D016	12429368	
0.5 / 0.37	1 / 0.75	1.5 / 1.1	2.5	1.6...2.5	32.5	MPW18-3-D025	12429369	
1 / 0.75	2 / 1.5	2 / 1.5	4	2.5...4	52	MPW18-3-U004	12429370	
1.5 / 1.1	3 / 2.2	4 / 3	6.3	4...6.3	82	MPW18-3-D063	12429371	
3 / 2.2	6 / 4.5	7.5 / 5.5	10	6.3...10	130	MPW18-3-U010	12429372	
5 / 3.7	10 / 7.5	12.5 / 9.2	16	10...16	208	MPW18-3-U016	12429373	
6 / 4.5	10 / 7.5	12.5 / 9.2	18	12...18	234	MPW18-3-U018	12429374	

MPW18i motor protective circuit breaker - magnetic - short circuit protection²⁾

Reference values for selecting protection of three-phase electric motors 60 Hz - 4 poles ¹⁾			Rated current I _n (A)	Instantaneous magnetic trip 13x I _n I _m (A)	Spring terminal		Weight kg
220-240 V cv / kW	380-415 V cv / kW	440-480 V cv / kW			Reference	Code	
-	-	-	0.16	2.08	MPW18i-3-C016	12429375	0.28
-	-	-	0.25	3.25	MPW18i-3-C025	12429376	
-	-	0.16 / 0.12	0.4	5.2	MPW18i-3-D004	12429377	
-	0.16 / 0.12	0.25 / 0.18	0.63	8.2	MPW18i-3-C063	12429388	
0.16 / 0.12	0.33 / 0.25	0.33 / 0.25	1	13	MPW18i-3-U001	12429389	
0.33 / 0.25	0.5 / 0.37	1 / 0.75	1.6	20.8	MPW18i-3-D016	12429391	
0.5 / 0.37	1 / 0.75	1.5 / 1.1	2.5	32.5	MPW18i-3-D025	12429392	
1 / 0.75	2 / 1.5	2 / 1.5	4	52	MPW18i-3-U004	12429393	
1.5 / 1.1	3 / 2.2	4 / 3	6.3	82	MPW18i-3-D063	12429394	
3 / 2.2	6 / 4.5	7.5 / 5.5	10	130	MPW18i-3-U010	12429395	
5 / 3.7	10 / 7.5	12.5 / 9.2	16	208	MPW18i-3-U016	12429396	
6 / 4.5	10 / 7.5	12.5 / 9.2	18	234	MPW18i-3-U018	12429397	

Notes: 1) The values are only valid for WEG W22 motors at S1 duty and service factor equal to 1.
2) For magnetic Motor Protective Circuit Breakers (MPW12i), it is necessary to use an overload protection device class 10.

MPW40 motor protective circuit breaker

Overview

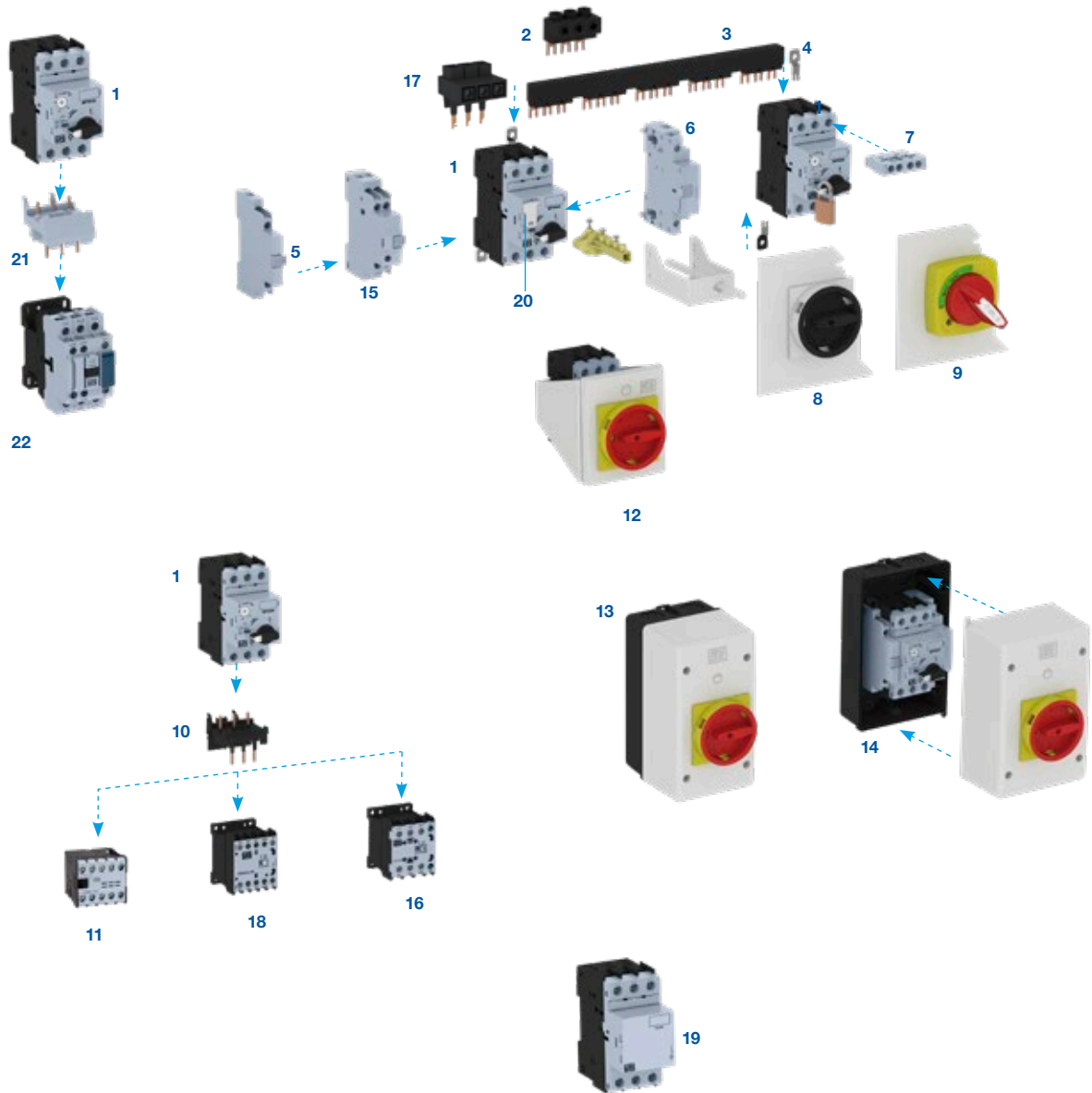

- | | |
|--|--|
| <ul style="list-style-type: none"> 1 - MPW40 motor protective circuit breaker 2 - Feeder terminal FTBBS 3 - Three-phase busbar BBS 4 - Push-in-lugs PLMP 5 - Side-mounted auxiliary contact block ACBS 6 - Undervoltage release URMP or shunt release SRMP 7 - Front mounted auxiliary contact block ACBF 8 - Door coupling rotary handle RMMP 9 - Door coupling rotary handle MRX 10 - Motor protective circuit breaker + contactor (CW07/CWC0/CWM) link modules 11 - Miniature contactor CW07 | <ul style="list-style-type: none"> 12 - Front plate FME55 13 - Insulated enclosure PE55 14 - Insulated enclosure LPE55 15 - Trip signaling block TSB 16 - Miniature contactor CWC025 17 - LST25 - Feeder terminal for "Type E" motor starter according to UL 18 - Miniature contactors CWC07...16 19 - Current limiter CLT32 20 - Scale cover SCMP 21 - Manual motor protector + CWB contactors link module 22 - Contactors CWB9...38 |
|--|--|

MPW40 motor protective circuit breaker



Selection table

MPW40 motor protective circuit breaker up to 40 A - thermomagnetic or magnetic only



- Allows the operation and overload and short circuit protection of electric motor
- Fixed short-circuit release 13 times the maximum circuit breaker rated current
- Phase-failure sensitivity according to IEC 60947-4-1
- Environment temperature compensation
- For use as main switch (IEC 60947-2)
- Self-protected against short circuit up to 6.3 A at 500 V_{AC}
- Thermomagnetic motor protective circuit breaker with overload protection (class 10)

MPW40 motor protective circuit breaker - thermomagnetic - overload and short-circuit protection

Reference values for selecting protection of three-phase electric motors 60 Hz - 4 poles ¹⁾			Rated current In (A)	Overload release setting 	Instantaneous magnetic trip 13x In 	Spring terminal		Weight kg
220-240 V cv / kW	380-415 V cv / kW	440-480 V cv / kW				Reference	Code	
-	-	-	0.16	0.1...0.16	2.08	MPW40-3-C016	12428084	0.36
-	-	-	0.25	0.16...0.25	3.25	MPW40-3-C025	12428085	
-	-	0.16 / 0.12	0.4	0.25...0.4	5.2	MPW40-3-D004	12428086	
-	0.16 / 0.12	0.25 / 0.18	0.63	0.4...0.63	8.2	MPW40-3-C063	12428087	
0.16 / 0.12	0.33 / 0.25	0.33 / 0.25	1	0.63...1	13	MPW40-3-U001	12429239	
0.33 / 0.25	0.5 / 0.37	1 / 0.75	1.6	1...1.6	20.8	MPW40-3-D016	12428108	
0.5 / 0.37	1 / 0.75	1.5 / 1.1	2.5	1.6...2.5	32.5	MPW40-3-D025	12428110	
1 / 0.75	2 / 1.5	2 / 1.5	4	2.5...4	52	MPW40-3-U004	12428112	
1.5 / 1.1	3 / 2.2	4 / 3	6.3	4...6.3	82	MPW40-3-D063	12428115	
3 / 2.2	6 / 4.5	7.5 / 5.5	10	6.3...10	130	MPW40-3-U010	12428117	
5 / 3.7	10 / 7.5	12.5 / 9.2	16	10...16	208	MPW40-3-U016	12428128	
7.5 / 5.5	12.5 / 9.2	15 / 11	20	16...20	260	MPW40-3-U020	12428129	
-	15 / 11	-	25	20...25	325	MPW40-3-U025	12428133	
12.5 / 9.2	20 / 15	20 / 15	32	25...32	416	MPW40-3-U032	12428131	
15 / 11	25 / 18.5	25 / 18.5	40	32...40	520	MPW40-3-U040	12382551	

MPW40i motor protective circuit breaker - magnetic - short circuit protection²⁾

Reference values for selecting protection of three-phase electric motors 60 Hz - 4 poles ¹⁾			Rated current In (A)	Instantaneous magnetic trip 13x In 	Spring terminal		Weight kg
220-240 V cv / kW	380-415 V cv / kW	440-480 V cv / kW			Reference	Code	
-	-	-	0.16	2.08	MPW40i-3-C016	12428137	0.36
-	-	-	0.25	3.25	MPW40i-3-C025	12428148	
-	-	0.16 / 0.12	0.4	5.2	MPW40i-3-D004	12428149	
-	0.16 / 0.12	0.25 / 0.18	0.63	8.2	MPW40i-3-C063	12428150	
0.16 / 0.12	0.33 / 0.25	0.33 / 0.25	1	13	MPW40i-3-U001	12428153	
0.33 / 0.25	0.5 / 0.37	1 / 0.75	1.6	20.8	MPW40i-3-D016	12428154	
0.5 / 0.37	1 / 0.75	1.5 / 1.1	2.5	32.5	MPW40i-3-D025	12428156	
1 / 0.75	2 / 1.5	2 / 1.5	4	52	MPW40i-3-U004	12428157	
1.5 / 1.1	3 / 2.2	4 / 3	6.3	82	MPW40i-3-D063	12428178	
3 / 2.2	6 / 4.5	7.5 / 5.5	10	130	MPW40i-3-U010	12428179	
5 / 3.7	10 / 7.5	12.5 / 9.2	16	208	MPW40i-3-U016	12428180	
7.5 / 5.5	12.5 / 9.2	15 / 11	20	260	MPW40i-3-U020	12428181	
-	15 / 11	-	25	325	MPW40i-3-U025	12428182	
12.5 / 9.2	20 / 15	20 / 15	32	416	MPW40i-3-U032	12428183	
15 / 11	25 / 18.5	25 / 18.5	40	520	MPW40i-3-U040	12382552	

Notes: 1) The values are only valid for WEG W22 motors at S1 duty and service factor equal to 1.

2) For magnetic Motor Protective Circuit Breakers (MPW40i), it is necessary to use an overload protection device class 10.

MPW40t motor protective circuit breaker

Selection table

- Allows the operation and overload and short circuit protection of inductive loads
- Used in the protection of transformers and electric motors with high starting currents
- Fixed short-circuit release 19 times the maximum circuit breaker rated current
- Breaking capacity up to 100 kA at 380-415 V_{AC} up to 10 A
- With phase-failure sensitivity according to IEC 60947-4-1
- With temperature compensation
- Thermomagnetic motor protective circuit breaker with overload protection (class 10)



MPW40t motor protective circuit breaker - thermomagnetic - overload and short-circuit protection

Reference values for selecting protection of three-phase electric motors 60 Hz - 4 poles ¹⁾			Rated current I _n (A)	Overload release setting I _n (A)	Instantaneous magnetic trip 19x I _n I _m (A)	Maximum breaking current at 415 V _{AC} I _{cu} (kA)	Screw terminal		Weight kg
220-240 V cv / kW	380-415 V cv / kW	440-480 V cv / kW					Reference	Code	
-	-	-	0.16	0.1...0.16	3.0	100	MPW40t-3-C016	12428358	0.36
-	-	-	0.25	0.16...0.25	4.8	100	MPW40t-3-C025	12428359	
-	-	0.16 / 0.12	0.4	0.25...0.4	7.6	100	MPW40t-3-D004	12428360	
-	0.16 / 0.12	0.25 / 0.18	0.63	0.4...0.63	12.0	100	MPW40t-3-C063	12428361	
0.16 / 0.12	0.33 / 0.25	0.33 / 0.25	1	0.63...1	19.0	100	MPW40t-3-U001	12429308	
0.33 / 0.25	0.5 / 0.37	1 / 0.75	1.6	1...1.6	30.4	100	MPW40t-3-D016	12428362	
0.5 / 0.37	1 / 0.75	1.5 / 1.1	2.5	1.6...2.5	47.5	100	MPW40t-3-D025	12428363	
1 / 0.75	2 / 1.5	2 / 1.5	4	2.5...4	76.0	100	MPW40t-3-U004	12428364	
1.5 / 1.1	3 / 2.2	4 / 3	6.3	4...6.3	119.7	100	MPW40t-3-D063	12428365	
3 / 2.2	6 / 4.5	7.5 / 5.5	10	6.3...10	190.0	100	MPW40t-3-U010	12428366	
5 / 3.7	10 / 7.5	12.5 / 9.2	16	10...16	304.0	50	MPW40t-3-U016	12428367	
7.5 / 5.5	12.5 / 9.2	15 / 11	20	16...20	380.0	50	MPW40t-3-U020	12428378	

Note: 1) The values are only valid for WEG W22 motors at S1 duty and service factor equal to 1.



MPW80 motor protective circuit breaker

Overview and selection table

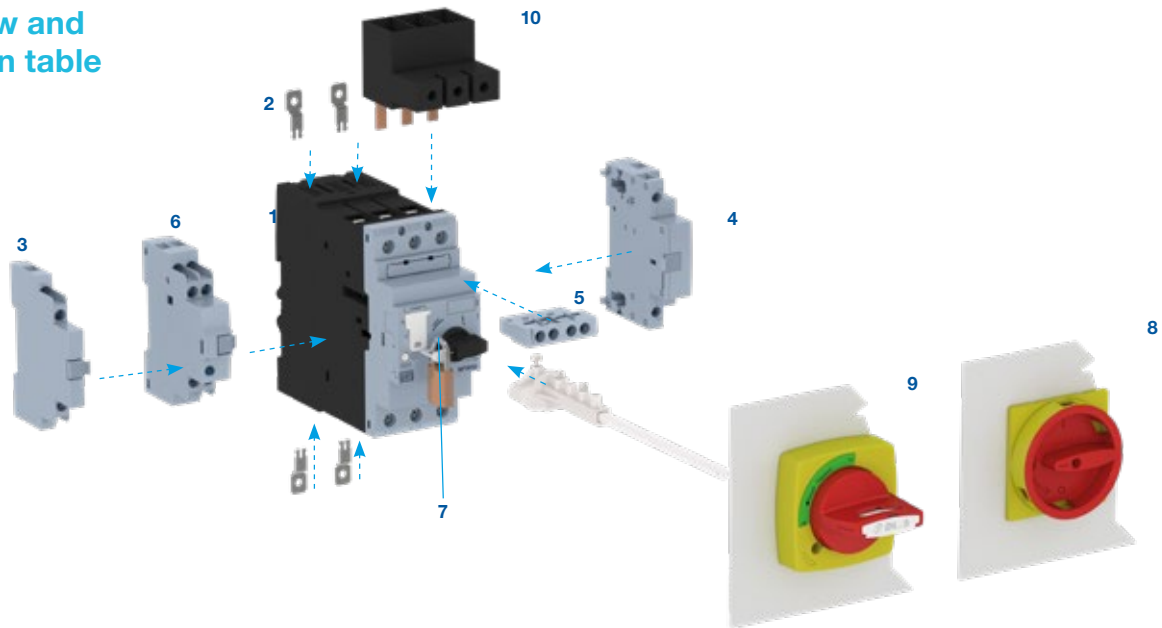

- 1 - MPW80 motor protective circuit breaker
- 2 - Push-in-lugs PLMP
- 3 - Side mounting auxiliary contact block ACBS
- 4 - Undervoltage release URMP or shunt release SRMP
- 5 - Front mounted auxiliary contact block ACBF
- 6 - Trip signaling block TSB
- 7 - Scale cover SCMP
- 8 - Door coupling rotary handle RMMP65
- 9 - Door coupling rotary handle MRX65
- 10 - LST25 - Feeder terminal for "Type E" motor starter according to UL

MPW80 motor protective circuit breaker up to 80 A - thermomagnetic or magnetic only

- Allows the operation and overload and short circuit protection of electric motor
- Fixed short-circuit release 13 times the maximum circuit breaker rated current
- Phase-failure sensitivity according to IEC 60947-4-1
- Environment temperature compensation
- For use as main switch (IEC 60947-2)
- Short-circuit breaking capacity from 65 kA up to 80 A at 380 V_{AC} according to IEC 60947-2
- Thermomagnetic motor protective circuit breaker with overload protection (class 10)



MPW80 motor protective circuit breaker - thermomagnetic - overload and short-circuit protection

Reference values for selecting protection of three-phase electric motors 60 Hz - 4 poles ¹⁾			Rated current In (A)	Overload release setting In (A)	Instantaneous magnetic trip 13x In Im (A)	"Box" terminal		Weight kg
220-240 V cv / kW	380-415 V cv / kW	440-480 V cv / kW				Reference	Code	
15 / 11	25 / 18.5	30 / 22	40	32...40	520	MPW80-3-U040	12425347	1.07
-	30 / 22	40 / 30	50	40...50	650	MPW80-3-U050	12425428	
25 / 18.5	40 / 30	50 / 37	65	50...65	845	MPW80-3-U065	12425429	
30 / 22	50 / 37	60 / 45	80	65...80	1,040	MPW80-3-U080 ³⁾	12501063	

MPW80i motor protective circuit breaker - magnetic - short circuit protection²⁾

Reference values for selecting protection of three-phase electric motors 60 Hz - 4 poles ¹⁾			Rated current In (A)	Instantaneous magnetic trip 13x In Im (A)	"Box" terminal		Weight kg
220-240 V cv / kW	380-415 V cv / kW	440-480 V cv / kW			Reference	Code	
15 / 11	25 / 18.5	30 / 22	40	520	MPW80i-3-U040	12425431	1.07
-	30 / 22	40 / 30	50	650	MPW80i-3-U050	12425432	
25 / 18.5	40 / 30	50 / 37	65	845	MPW80i-3-U065	12425434	
30 / 22	50 / 37	60 / 45	80	1,040	MPW80i-3-U080 ³⁾	12501066	

Notes: 1) The values are only valid for WEG W22 motors at S1 duty and service factor equal to 1.
 2) For magnetic Motor Protective Circuit Breakers (MPW80i), it is necessary to use an overload protection device class 10.
 3) MPW80-3-U080 and MPW80i-3-U080i on certification process.

MPW100 motor protective circuit breaker

Overview and selection table

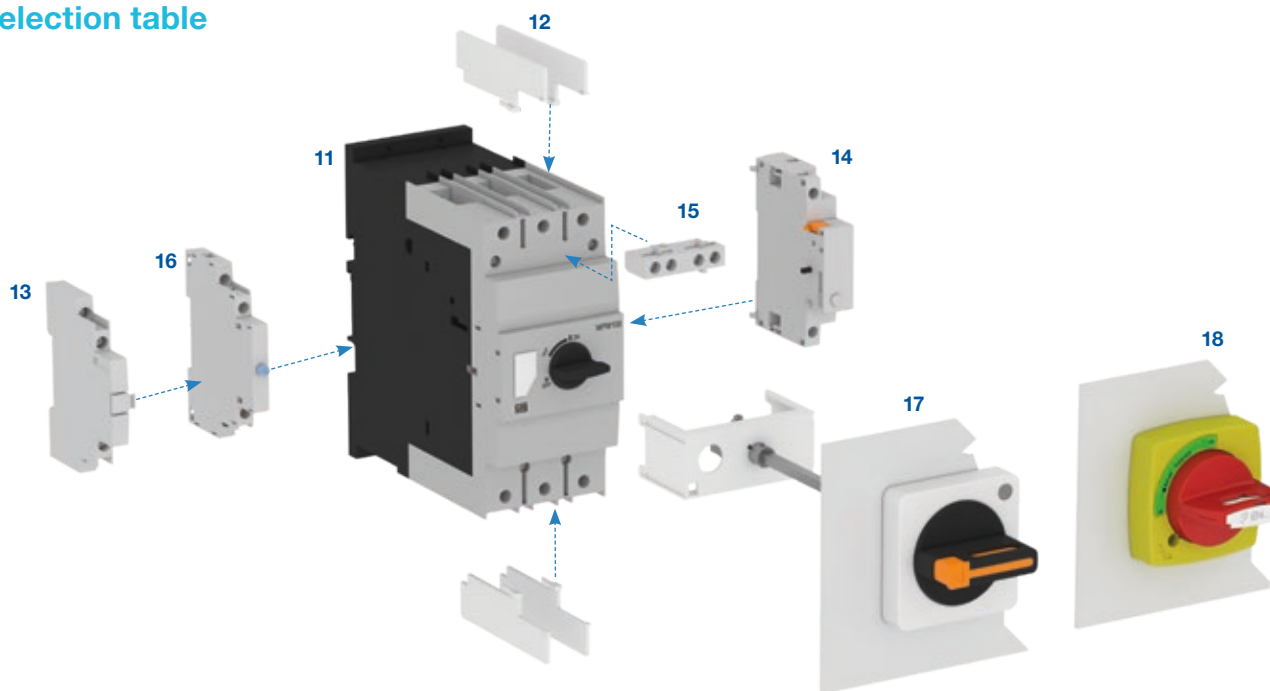

- 11 - MPW100 motor protective circuit breaker
- 12 - IB insulators MPW100
- 13 - Side-mounted auxiliary contact block ACBS
- 14 - Undervoltage release URMP or shunt release SRMP_MPW100

- 15 - Front mounted auxiliary contact block ACBF MPW100
- 16 - Trip signaling block TSB_MPW100
- 17 - Door coupling rotary handle MR MPW100
- 18 - Door coupling rotary handle MRX100

MPW100 motor protective circuit breaker - thermomagnetic

- Allows the operation and overload and short circuit protection of electric motor
- Fixed short-circuit release 13 times the maximum circuit breaker rated current
- With phase-failure sensitivity according to IEC 60947-4-1
- With temperature compensation
- For use as main switch (IEC 60947-2)
- Self-protected against short circuit up to 100 A at 220/240 V_{AC}
- Short-circuit breaking capacity of 50 kA (I_{cu}) at 440 V_{AC} according to IEC 60947-2
- UL/CSA certifications
- Thermomagnetic motor protective circuit breaker with overload protection (class 10)





MPW100 motor protective circuit breaker - thermomagnetic - overload and short-circuit protection

Reference values for selecting protection of three-phase electric motors 60 Hz - 4 poles ¹⁾			Rated current	Overload release setting	Instantaneous magnetic trip 13x I _n	"Box" terminal		Weight kg
220-240 V cv / kW	380-415 V cv / kW	440-480 V cv / kW	I _n (A)	I _n (A)	I _m (A)	Reference	Code	
25 / 18.5	50 / 37	60 / 45	75	55...75	975	MPW100-3-U075	10076551	2.2
30 / 22	60 / 45	75 / 55	90	70...90	1,170	MPW100-3-U090	10076552	
40 / 30	60 / 45	75 / 55	100	80...100	1,300	MPW100-3-U100	10047295	

Note: 1) The values are only valid for WEG W22 motors at S1 duty and service factor equal to 1.



Accessories

Front auxiliary contact blocks - ACBF¹⁾

For use with	Illustrative picture	Auxiliary contacts		Reference	Code	Weight kg
		NO	NC			
MPW12		1	1	ACBF-11S	12463910	0.024
MPW18 MPW40 MPW80				ACBF-11	12463886	
MPW100				ACBF-11 MPW100	10047296	0.018

Note: 1) After assembly, the front auxiliary contact blocks can not be removed.

Left side auxiliary contact block - ACBS

For use with	Illustrative picture	Auxiliary contacts		Reference	Code	Weight kg
		NO	NC			
MPW12		1	1	ACBS-11S	12463908	0.045
		2	-	ACBS-20S	12463913	
		-	2	ACBS-02S	12463915	
MPW18 MPW40 MPW80		1	1	ACBS-11	12463909	0.030
		2	-	ACBS-20	12463912	
		-	2	ACBS-02	12463914	
MPW100		1	1	ACBS-11 MPW100	10047297	0.030
		2	-	ACBS-20 MPW100	10076555	
		-	2	ACBS-02 MPW100	10076556	

Block modules for motor protective circuit breaker assembly + contactors - ECCMP

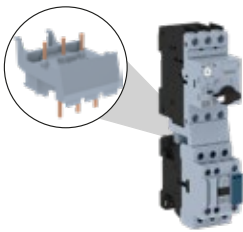
For use with	Illustrative picture	Description	Contactors	Reference	Code	Weight kg
MPW18		For direct connection (electrical and mechanical) of motor protective circuit breakers to screw terminal.	CWC07...16 (AC/DC coil)	ECCMP-C016	10867179	0.025
MPW40			CWB9...38 (AC coil)	ECCMP-18B38	12462672	
			CW07 (AC coil)	ECCMP-07	10046506	
			CWC07...16 (AC/DC coil)	ECCMP-C0	10047217	
			CWC025 (AC coil)	ECCMP-C025	10689937	
			CWM9...25 (AC coil)	ECCMP-25	10409822	
			CWM32/40 (AC coil)	ECCMP-32	10075736	
			CWB9...38 (AC coil)	ECCMP-40B38	12462673	
			CWB9...38 (DC coil)	ECCMP-40B38DC	12462674	
MPW80			CWB40...80 (AC/DC coil)	ECCMP-80B80	13520507	0.029

Accessories

Undervoltage release - URMP¹⁾²⁾

For use with	Illustrative picture	Description	Voltages and frequencies	Reference	Code	Weight kg
MPW12 MPW18 MPW40 MPW80		<ul style="list-style-type: none"> - Operating voltage: $>0.85...1.1 \times U_e$ - Non-operating voltage: $<0.35...0.7 \times U_e$ - Right side assembly only. 	220 V 50 / 60 Hz	URMP D23	12463885	0.130
			24 V 50 / 60 Hz	URMP D02	12463884	
			110 V 50 Hz / 120 V 60 Hz	URMP V18	12463874	
			110-115 V 50 Hz / 127 V 60 Hz	URMP V19	12463875	
			180 V 50 Hz / 208 V 60 Hz	URMP V23	12463876	
			190 V 50 Hz / 220 V 60 Hz	URMP V26	12463877	
			208 V 50 Hz / 240 V 60 Hz	URMP V30	12463879	
			220 V 50 Hz / 255 V 60 Hz	URMP V32	12463878	
			230-240 V 50 Hz / 277 V 60 Hz	URMP V37	12463880	
			325 V 50 Hz / 380 V 60 Hz	URMP V41	12463881	
			380 V 50 Hz / 440 V 60 Hz	URMP V42	12463882	
400-415 V 50 Hz / 480 V 60 Hz	URMP V47	12463883				
MPW100		<ul style="list-style-type: none"> - Operating voltage: $>0.85...1.1 \times U_e$ - Non-operating voltage: $<0.35...0.7 \times U_e$ - Right side assembly only. 	110 V 50 Hz / 120 V 60 Hz	URMP V18 MPW100	10186875	0.018
			220-230 V 50 Hz / 240-260 V 60 Hz	URMP V33 MPW100	10186876	
			380-400 V 50 Hz / 440-460 V 60 Hz	URMP V43 MPW100	10186877	
			200 V 50 Hz / 200-220 V 60 Hz	URMP VD1 MPW100	11028882	

Shunt release - SRMP¹⁾²⁾

For use with	Illustrative picture	Description	Voltages and frequencies	Reference	Code	Weight kg
MPW12 MPW18 MPW40 MPW80		<ul style="list-style-type: none"> - Operating voltage: $0.7...1.1 \times U_e$ - Right side assembly only. 	20-24 V 50/60 Hz	SRMP D51	12463869	0.130
			40-48 V 50/60 Hz	SRMP D54	12463870	
			100-127 V 50/60 Hz	SRMP D59	12463871	
			200-240 V 50/60 Hz	SRMP D65	12463872	
			365-440 V 50/60 Hz	SRMP D69	12463873	
MPW100			110 V 50 Hz / 120 V 60 Hz	SRMP V18 MPW100	10186872	0.040
			220-230 V 50 Hz / 240-260 V 60 Hz	SRMP V33 MPW100	10186873	
			380-400 V 50 Hz / 440-460 V 60 Hz	SRMP V43 MPW100	10186874	
			200 V 50 Hz / 200-220 V 60 Hz	SRMP VD1 MPW100	11028884	

Notes: 1) Available with screw terminal only.
2) Another voltages under request.

Accessories

Trip signaling block - TSB¹⁾

For use with	Illustrative picture	Description	Reference	Code	Weight kg
MPW18 MPW40 MPW80		- Equipped with 2 contacts (1NO+1NC) for trip signaling and other 2 contacts (1NO+1NC) for short-circuit trip signaling. - To reset the circuit breaker after a short-circuit, the flag must be manually reset after the cause of the failure has been solved. - Lateral auxiliary contacts can be assembled together with the trip signaling block. - Left side assembly only.	TSB	12463916	0.130
MPW100		- Equipped with 2 contacts (1NO+1NC) for overload or short-circuit trip signaling. - Left side assembly only.	TSB AT-11 MPW100 ²⁾	10047298	0.040
		- Equipped with 2 contacts (1NO+1NC) for short-circuit trip signaling only. - Left side assembly only.	TSB SC-11 MPW100 ²⁾	10076559	

Notes: 1) TSB block limits the number of auxiliary contact blocks to 1 (ACBF and ACBS cannot be used simultaneously).
2) It is not possible to use TSB AT-11 MPW100 and TSB SC-11 MPW100 on the same MPCB.



Current limiter - CLT32

For use with	Illustrative picture	Description	Reference	Code	Weight kg
MPW40		- For protecting electrical circuits where high short-circuit breaking capacity is required: 100 kA at 500 Vac. <i>Note: this accessory must be used together with a motor protective circuit breaker up to 32 A.</i>	CLT32	12462918	0.310

Insulators for UL - IB

For use with	Illustrative picture	Description	Reference	Code	Weight kg
MPW100		Insulators for increasing the creepage distance and clearances according to UL requirements. Package with 4 pieces.	IB MPW100	10213096	0.010

Feeders for Type E motor starters

For use with	Illustrative picture	Description	Reference	Code	Weight kg
MPW40		- Block module for "Type E" according to UL (LST25+MPW up to 32 A+TSB). - Rated insulation voltage: 690 Vac. - Rated operational current (I _o): 63 A. - Terminals: 8-20 AWG.	LST25	10047102	0.055
MPW80		- Block module for "Type E" according to UL (LST65+MPW up to 65 A+TSB). - Rated insulation voltage: 690 Vac. - Rated operational current (I _o): 120 A. - Terminals: 4-8 AWG.	LST65	11112690	0.179

Accessories

Three-phase feeder terminal - FTBBSP, LST25 and LST65

For use with	Illustrative picture	Description	Reference	Code	Weight kg
MPW18 MPW40		<ul style="list-style-type: none"> - For feeding the busbar. - Rated insulation voltage: 690 V_{ac}. - Rated operational current (I_o): 63 A. - Terminals: 6-25 mm² rigid wire and 6-16 mm² flexible wire with terminal. 	FTBBS	17441416	0.047

Three-phase busbars for circuit breakers without side fitted auxiliary contacts - BBSP45

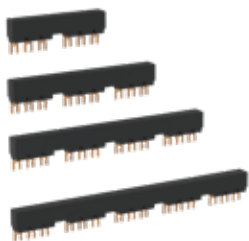
For use with	Illustrative picture	Description	Number of circuit breakers	Reference	Code	Weight kg
MPW18 MPW40		<ul style="list-style-type: none"> - For parallel blocking of side-by-side mounted circuit breakers with screw terminal of the same model without side auxiliary contacts. - Enables the use of frontal auxiliary contact block ACBF-11. - Rated insulation voltage: 690 V_{ac}. - Rated operational current (I_o): 63 A. 	2	BBS45-2	13451023	0.028
			3	BBS45-3	13451024	0.055
			4	BBS45-4	13451025	0.074
			5	BBS45-5	13451026	0.097

Three-phase busbars for motor protective circuit breakers with side fitted auxiliary contacts - BBSP54

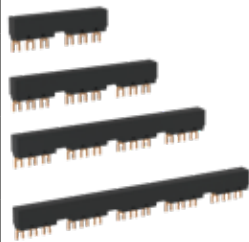
For use with	Illustrative picture	Description	Number of circuit breakers	Reference	Code	Weight kg
MPW18 MPW40		<ul style="list-style-type: none"> - For parallel connection of circuit breakers with screw terminals of the same model mounted side-by-side. - Enables the use of side auxiliary contact block ACBS and ACBF mounted on each motor protective circuit breaker. - Rated insulation voltage: 690 V_{ac}. - Rated operational current (I_o): 63 A. 	2	BBS54-2	13451027	0.032
			3	BBS54-3	13451168	0.058
			4	BBS54-4	13451169	0.085
			5	BBS54-5	13451170	0.112

Shrouded for unused terminals - CSDP

For use with	Illustrative picture	Description	Reference	Code	Weight kg
BBSP45 BBSP54		Protection against direct contact with energized terminals without the use on the busbars BBSP.	CSD	10073627	0.003

Scale cover - SCMP





For use with	Illustrative picture	Description	Reference	Code	Weight kg
MPW12 MPW18 MPW40 MPW80		Protects the current adjustment dial of thermomagnetic motor protective circuit breaker against direct contact and prevents changes in the adjusted current by means of a seal installed by the user.	SCMP	10186290	0.005

Accessories

Push-in-lugs - PLMP

For use with	Illustrative picture	Description	Reference	Code	Weight kg
MPW12 MPW18 MPW40 MPW80		For direct assembly of motor protective circuit breaker into a surface with screws. <i>Note: for the MPW80 motor protective circuit breaker, use 2 PLMP sets.</i>	PLMP	10185925	0.005

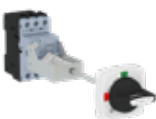
Door coupling rotary handle - RMMP, MRX and MR





For use with	Illustrative picture	Description	Handle color	Reference	Code	Weight kg
MPW40		<ul style="list-style-type: none"> - Degree of protection IP55. - Shows circuit breaker position "I" (ON), "O" (OFF) and TRIP (Tripped). - Panel door can only be opened in OFF position. - Adjustable shaft length. There are two standard shaft sizes: 130 mm (Model 130) and 330 mm (Model 330). - Up to three padlocks can be used in the OFF. 	Black	RMMP-130	10185921	0.140
			Red	RMMP-330E	10185922	0.175
MPW80		<ul style="list-style-type: none"> - This blocks the circuit breaker operation and opens the panel door. - Handle can be mounted on panels with a thickness of 1 to 5 mm. - Handle can be mounted even with circuit breaker in the position rotating 90°. 	Black	RMMP65-130	11068497	0.139
			Black	RMMP65-330	11068519	0.175
			Red	RMMP65-130E	11068518	0.139
			Red	RMMP65-330E	11068520	0.175
MPW40		<ul style="list-style-type: none"> - Degree of protection IP65/NEMA4X. - Shows circuit breaker position "I" (ON), "O" (OFF) and TRIP (Tripped). - Panel door can be opened in OFF position. In ON position opening is possible pressing the release pin (for thermometry purposes). - Adjustable shaft length. There are two standard shaft sizes: 130 mm (Model 130) and 330 mm (Model 330). - Padlock can be used. 	Black	MRX-130	11051796	0.185
			Red	MRX-330E	10857691	0.185
MPW80		<ul style="list-style-type: none"> - This blocks the circuit breaker operation and opens the panel door. - Can be mounted on panels with thickness of 1...5 mm. 	Black	MRX65-130	11068521	0.250
			Red	MRX65-330E	11068525	0.280
MPW100			Black	MRX100-130	11152799	0.151
			Red	MRX100-130E	11152800	0.151
MPW100		<ul style="list-style-type: none"> - Degree of protection IP65. - Shows circuit breaker position "I" (ON), "O" (OFF) and TRIP (Tripped). - Panel door can be opened in the ON position (thermometry). - Adjustable shaft length. There are two standard shaft sizes: 115 mm (Model 115) and 315 mm (Model 315). - Padlocks can be used. 	Gray	MR MPW100-115	10609710	0.170
			Gray	MR MPW100-315	10609711	0.200

Front plate - FME55

For use with	Illustrative picture	Description	Handle color	Reference	Code	Weight kg
MPW40		<ul style="list-style-type: none"> - Front plate for electrical panel door or side mounting. - Front degree of protection IP55. - Rotary handle on the cover connected to the MPW handle. - Handle can be locked with up to 3 padlocks in the "OFF" position. - Allows installing: MPW + ACBF11/Lamp PL + ACBS + URMP/SRMP. - Can be mounted on panels with a thickness of 1...8 mm. - Color: cover (gray RAL 7035). 	Black	FME55	10186425	0.41
			Red	FME55E	10186426	0.41

Accessories

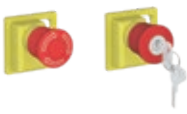
Insulated enclosures - PE

For use with	Illustrative picture	Description	Terminals	Handle color	Reference	Code	Weight kg	
MPW12 MPW18		<ul style="list-style-type: none"> - Empty plastic enclosure. - Degree of protection IP41. - 2 inputs/outputs PG16 for cable glands on top and bottom, and 2 inputs/outputs ØM20 in the back. - Allows installing: MPW + ACBF11/Lamps PL+ ACBS. - Color: cover (gray RAL 7035) and base (black RAL 7021). 	-	-	PE41	10831536	0.41	
			Ground	-	PE41G	10831606	0.41	
			Ground and Neutral	-	PE41GN	10831607	0.41	
		<ul style="list-style-type: none"> - Empty plastic enclosure. - Degree of protection IP66. - 2 inputs/outputs PG16 for cable glands on top and bottom, and 2 inputs/outputs ØM20 in the back. - Allows installing: MPW + ACBF11/Lamp PL + ACBS. - Color: cover (gray RAL 7035) and base (black RAL 7021). 	-	-	PE66	10831535	0.41	
			Ground	-	PE66G	10831643	0.41	
			Ground and Neutral	-	PE66GN	10831700	0.41	
		- Allows raising the degree of protection of the insulated enclosure PE41 (IP41) to IP66	-	-	KIT66PE	10853867	0.016	
		- Emergency stop button - turn to release	Assembled in enclosures model PE41 or PE66.	-	Red	FESTPE	11659180	0.060
		- Emergency stop button - push to release				FESPPE	11941110	0.060
		- Emergency stop button - key to release				FESYPE	11659178	0.125
MPW40		<ul style="list-style-type: none"> - Empty plastic enclosure. - Degree of protection IP55. - Allows installing: MPW + ACBF11/Lamp PL + ACBS. - 2 inputs/outputs for cable gland ØPG16 on top/bottom, and 2 inputs/outputs ØM20 in the back. - Rotary handle on the cover connected to the MPW handle. - Handle can be locked with up to 3 padlocks in the "OFF" position. - Color: cover (gray RAL 7035) and base (black RAL 7021). 	-	Black	PE55	10185915	0.44	
			-	Red	PE55E	10185916	0.44	
			Ground	Black	PE55G	10185917	0.54	
				Red	PE55G-E	10185918	0.54	
			Ground and Neutral	Black	PE55GN	10185919	0.45	
				Red	PE55GN-E	10185920	0.45	

Insulated enclosures - LPE

For use with	Illustrative picture	Description	Terminals	Handle color	Reference	Code	Weight kg
MPW40		<ul style="list-style-type: none"> - Front plate for electrical panel door or side mounting. - Front degree of protection IP55. - Rotary handle on the cover connected to the MPW handle. - Handle can be locked with up to 3 padlocks in the "OFF" position. - Allows installing: MPW + ACBF11/Lamp PL + ACBS + URMP/SRMP. - Can be mounted on panels with a thickness of 1...8 mm. - Color: cover (gray RAL 7035). 	-	Black	LPE55	10211364	0.44
			-	Red	LPE55E	10666515	0.44
			Ground	Black	LPE55G	10651171	0.54
				Red	LPE55G-E	10666538	0.54
			Ground and Neutral	Black	LPE55GN	10211368	0.45
				Red	LPE55GN-E	10666540	0.45

Pilot light - PL

For use with	Illustrative picture	Voltage	Color	Reference	Code	Weight kg
FME PE LPE		24 V 50/60 Hz / 24 Vdc	Red	PL24 E26	10046226	0.005
			Green	PL24G E26	10046228	
			White	PL24W E26	10046230	
		110-130 V 50/60 Hz	Red	PL130 D61	10045246	
			Green	PL130G D61	10046229	
			White	PL130W D61	10046231	
		210-230 V 50/60 Hz	Red	PL230 D78	10045247	
			Green	PL230G D78	10186288	
			White	PL230W D78	10211181	
		400-560 V 50/60 Hz	Red	PL560 D79	10046227	
			Green	PL560G D79	10211180	
			White	PL560W D79	10046232	

Technical data

Models	MPW12	MPW12 ⁽⁴⁾	MPW18	MPW18 ⁽⁴⁾
Maximum rated current I_{nmax} (I_g)	12 A	12 A	18 A	18 A
Number of poles	3			
Short-circuit release	13 x I_g max.			
Rated operational voltage U_e	690 V ⁽¹⁾			
Rated frequency	50/60 Hz			
Rated insulation voltage U_i	690 V			
Rated impulse withstand voltage U_{imp}	6 kV			
Use category	IEC 60947-2 (circuit breaker)		A	
	IEC 60947-4-1 (motor starter)		AC-3	
Tripping test	Yes			
Overload protection	Yes	No	Yes	No
Phase failure sensitivity (IEC 60947-4-1)	Yes	No	Yes	No
Tripping indication	No			
Tripping class (IEC 60947-4-1)	10	-	10	-
Maximum operation per hour	Operations / hour		15	
Altitude (m)	2,000			
Degree of protection (IEC 60529)	IP20			
Mechanical life	Number of operations		100,000	
Electrical life	Number of operations		100,000	
Permissible ambient temperature				
Transport and storage	-50...+80 °C			
Operation ⁽²⁾	-20...+70 °C			
Temperature compensation (IEC 60947-4-1)	-20...+60 °C	-	-20...+60 °C	-
Power dissipation per circuit breaker				
C016 / C025 / D004 / C063 / U001 / D016 / D025 / U004	≤4 A	7 W		
D063 / U010	≤10 A	8 W		
U012	≤12 A ⁽³⁾	10 W	-	
U016	≤16 A	-	14 W	
U018	≤18 A	-	12 W	
Resistance to impact (IEC 60068-2-27)	15 g		15 g	
Standards				
IEC 60947-1	Yes			
IEC 60947-2	Yes			
IEC 60947-4-1	Yes			
Connection				
Terminal type	Spring		Philips screws (N° 2)	
Tightening torque	N.m	-		1.2...1.7
	lb.in	-		11...16
Dimensions				
Width (mm)	45			
Height (mm)	100		97	
Depth (mm)	77			

Notes: 1) 500 V with plastic enclosures.

2) Reduce current for temperatures exceeding +60 °C (87% for 70 °C).

3) Only available with spring terminal.

4) For magnetic Motor Protective Circuit Breakers, it is necessary to use an overload protection device class 10.

Technical data

Models	MPW40	MPW40i ³⁾	MPW40t
Maximum rated current Inmax (I _e)	40 A		20 A
Number of poles	3		
Short-circuit release	13 x I _e max.		19 x I _e max.
Rated operational voltage U _e	690 V ¹⁾		
Rated frequency	50/60 Hz		
Rated insulation voltage U _i	690 V		
Rated impulse withstand voltage U _{imp}	6 kV		
Use category	IEC 60947-2 (circuit breaker)		A
	IEC 60947-4-1 (motor starter)		AC-3
Tripping test	Yes		
Overload protection	Yes	No	Yes
Phase failure sensitivity (IEC 60947-4-1)	Yes	No	Yes
Tripping indication	Yes		
Tripping class (IEC 60947-4-1)	10	-	10
Maximum operation per hour	Operations / hour		15
Altitude (m)	2,000		
Degree of protection (IEC 60529)	IP20		
Mechanical life	Number of operations		100,000
Electrical life	Number of operations		100,000
Permissible ambient temperature			
Transport and storage	-50...+80 °C		
Operation ²⁾	-20...+70 °C		
Temperature compensation (IEC 60947-4-1)	-20...+60 °C	-	-20...+60 °C
Power dissipation per circuit breaker			
C016 / C025 / D004 / C063 / U001 / D016 / D025 / U004	≤4 A	7 W	
D063 / U010	≤10 A	8 W	
U016	≤16 A	12 W	
U020	≤20 A	12 W	
U025 / U032	≤32 A	15 W	
U040	≤40 A	11 W	
Resistance to impact (IEC 60068-2-27)	15 g		
Standards			
IEC 60947-1	Yes		
IEC 60947-2	Yes		
IEC 60947-4-1	Yes		
Connection			
Terminal type	Philips screws (N° 2)		
Tightening torque	N.m	2...2.5	
	lb.in	18...22	
Dimensions			
Width (mm)	45		
Height (mm)	97		
Depth (mm)	98		

Notes: 1) 500 V with plastic enclosures.

2) Reduce current for temperatures exceeding +60 °C (87% for 70 °C).

3) For magnetic Motor Protective Circuit Breakers, it is necessary to use an overload protection device class 10.

Technical data

Models		MPW80	MPW80i ³⁾	MPW100
Maximum rated current I_n		80 A	80 A	100 A
Number of poles		3		
Short-circuit release		13 x I_n max.		
Rated operational voltage U_e		690 V		
Rated frequency		50/60 Hz		
Rated insulation voltage U_i		690 V		1,000 V
Rated impulse withstand voltage U_{imp}		6 kV		8 kV
Use category	IEC 60947-2 (circuit breaker)	A		
	IEC 60947-4-1 (motor starter)	AC-3		
Tripping test		Yes		
Overload protection		Yes	No	Yes
Phase failure sensitivity (IEC 60947-4-1)		Yes	No	Yes
Tripping indication		Yes		
Tripping class (IEC 60947-4-1)		10	-	10
Maximum operation per hour	Operations / hour	15		25
Altitude (m)		2,000		
Degree of protection (IEC 60529)		IP20 ¹⁾		
Mechanical life	Number of operations	50,000		
Electrical life	Number of operations	25,000		
Permissible ambient temperature				
Transport and storage		-50...+80 °C		
Operation ²⁾		-20...+70 °C		-20...+60 °C
Temperature compensation (IEC 60947-4-1)		-20...+60 °C	-	-20...+60 °C
Power dissipation per circuit breaker				
U040	≤40 A	12 W		-
U050	≤50 A	13 W		-
U065	≤65 A	13 W		-
U075	≤75 A	-		25 W
U080	≤80 A	18 W		-
U090	≤90 A	-		29 W
U100	≤100 A	-		29 W
Resistance to impact (IEC 60068-2-27)		15 g		25 g
Standards				
IEC 60947-1		Yes		
IEC 60947-2		Yes		
IEC 60947-4-1		Yes		
Connection				
Terminal type		Box		
Tightening torque	N.m	6		
	lb.in	55		55
Terminal type		Allen (4 mm)		
Dimensions				
Width (mm)		54		70
Height (mm)		125		165
Depth (mm)		157		171

Notes: 1) Main terminals.

2) Reduce current for temperatures exceeding +60 °C (87% for 70 °C).

3) For magnetic Motor Protective Circuit Breakers (MPW80i), it is necessary to use an overload protection device class 10.

Technical data





Altitudes - correction factors

The MPW motor protective circuit breakers do not undergo any changes to their specified performance when applied at an altitude of up to 2,000 meters above sea level.

However, as the altitude increases, the atmospheric properties vary in terms of dielectric rigidity and pressure. Therefore, current and voltage correction factors must be applied according to the table on the right:

Altitude (above sea level) - h	Rated operational voltage U_e	Current correction factor L_u
$h \leq 2,000$ m	690 V	1 x I_n
$2,000 < h \leq 3,000$ m	550 V	0.96 x I_n
$3,000 < h \leq 4,000$ m	480 V	0.93 x I_n
$4,000 < h \leq 5,000$ m	420 V	0.90 x I_n

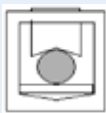
Main terminal capacity

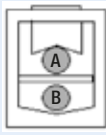
Models		MPW12		
Solid wire or flexible cable with wire ferrules		1x or 2x 1...1.5 mm ² / 1x or 2x 18...16 AWG		
		1x or 2x 1...1.5 mm ² / 1x or 2x 18...16 AWG		
Models		MPW18	MPW40 (≤32 A)	MPW40 (32...40 A)
Screw type		Phillips screw N° 2		
Solid wire or flexible cable with wire ferrules		1x or 2x 1...4 mm ² 1x or 2x 18...12 AWG	1x or 2x 1...2.5 mm ² 1x or 2x 2.5...6 mm ² 1x or 2x 14...10 AWG	1x or 2x 1...2.5 mm ² 1x or 2x 2.5...6 mm ² 1x 10mm ² 1x or 2x 14...10 AWG
		Tightening torque		1.2...1.7 N.m / 11...16 lb.in
Models		MPW80		MPW100
Screw type		Allen 4 mm		Allen 4 mm
Solid wire or flexible cable with wire ferrules		1x 1.5...35 mm ² 1x 12...2 AWG		1x 2.5...70 mm ² 1x 12...2/0 AWG
Flexible cable without wire ferrules		1x 1...35 mm ² 1x 12...2 AWG		1x 2.5...50 mm ² 1x 12...1/0 AWG
Solid wire or flexible cable with wire ferrules		1x 2.5...35 mm ² 1x 12...2 AWG		-
Flexible cable without wire ferrules		1x 6...35 mm ² 1x 12...2 AWG		-
Solid wire or flexible cable with wire ferrules		A: 1...35 mm ² / B: 2.5...35 mm ² A: 12...2 AWG / B: 12...2 AWG		A: 1x 2.5...50 mm ² / B: 1x 2.5...50 mm ² A: 1x 12...1/0 AWG A: 1x 12...1/0 AWG
Flexible cable without wire ferrules		A: 1.5...35 mm ² / B: 6...35 mm ² A: 12...2 AWG / B: 12...2 AWG		A: 1x 2.5...35 mm ² / B: 1x 2.5...35 mm ² A: 1x 10...2 AWG A: 1x 10...2 AWG
Tightening torque		6.0 N.m / 55 lb.in		4...6.0 N.m / 35...53 lb.in

Technical data

Auxiliary contact block

References	ACBF-11 (S)			ACBS- __ (S), TSB			
For use with	MPW12...80						
Rated insulation voltage U_i	250 V			690 V			
Utilization category	24 V _{AC}	220-230 V _{AC}		24 V _{AC}	30 V _{AC}	400 V _{AC}	690 V _{AC}
AC-15	2 A	0.5 A		6 A	4 A	3 A	1 A
AC-12	2.5 A	2.5 A		10 A	10 A	10 A	10 A
DC-13	24 V _{DC}	48 V _{DC}	60 V _{DC}	24 V _{DC}	110 V _{DC}	220 V _{DC}	440 V _{DC}
	1 A	0.3 A	0.15 A	2 A	0.5 A	0.25 A	0.1 A
Terminal type	Flat		Spring	Flat		Spring	
Screw type	Phillips (N° 2)		-	Phillips (N° 2)		440 V _{DC}	
Tightening torque	1 N.m (8.8 lb.in)		-	1 N.m (8.8 lb.in)		0.1 A	
Rigid cable	1 or 2 x (0.5...1.5 mm ²) 1 or 2 x (0.75...2.5 mm ²) 1 or 2 x (18...14 AWG)	1 or 2 x (1...1.5 mm ²) 1 or 2 x (18...16 AWG)		1 or 2 x (0.5...1.5 mm ²) 1 or 2 x (0.75...2.5 mm ²) 1 or 2 x (18...14 AWG)		1 or 2 x (1...1.5 mm ²) 1 or 2 x (18...16 AWG)	
Flexible cable		-				-	
Cable without terminal ¹⁾		1 or 2 x (1 mm ²) 1 or 2 x (18 AWG)				1 or 2 x (1 mm ²) 1 or 2 x (18 AWG)	
Back-up fuses gL/gG	10 A						

Note: 1) Mandatory use for ACBS(s) and ACSF-11(S).

References	ACBF-11 MPW100		ACBS- __ MPW100/TSB __ MPW100	
For use with	MPW100			
Rated insulation voltage U_i	250 V		690 V	
Regime:	240 V _{AC}		24 V _{AC}	240 V _{AC}
AC-15	3 A		6 A	4 A
DC-13	24 V _{DC}	220 V _{DC}	24 V _{DC}	220 V _{DC}
	1 A	0.1 A	2 A	0.25 A
Terminal type	Flat			
Screw type	Phillips (N° 2)			
Tightening torque	0.8...1.2 N.m (7...10 lb.in)			
Rigid cable	1 (0.5...2.5 mm ² / 20...14 AWG)		1 or 2 x (0.5...2.5 mm ² / 20...14 AWG)	
Flexible cable	1 (0.5...4 mm ² / 20...10 AWG) or 2 (0.75...2.5 mm ² / 18...14 AWG)			
Back-up fuses gL/gG	16 A			

Undervoltage release

References	URMP	URMP __ MPW100
For use with	MPW12...80	MPW100
Rated insulation voltage U_i	690 V	
Operating voltage (enable to switch on circuit breaker)	0.85...1.1x U_e	
Non-operating voltage (guarantees circuit breaker switch OFF)	0.7...0.35x U_e	
Energization consumption	20.2 VA / 13 W	8.5 VA / 6 W
Consumption	7.2 VA / 2.4 W	3 VA / 1.2 W
Maximum opening time	20ms	
Terminal type	Flat	
Screw type	Phillips (N° 2)	
Tightening torque	1 N.m (8.8 lb.in)	0.8...1.2 N.m (7...10 lb.in)
Rigid cable	1 or 2 x (0.5...1.5 mm ²). 1 or 2 x (0.75...2.5 mm ²)	
Flexible cable	1 or 2 x (18...14 AWG)	
Back-up fuses gL/gG	10 A	

Technical data

Shunt release

References	SRMP	SRMP _ MPW100
For use with	MPW12...80	MPW100
Rated insulation voltage U_i	690 V	
Operating voltage (guarantees circuit breaker switch OFF)	0.7...1.1x U_e	
Energization consumption	20.2 VA / 13 W	8.5 VA / 6 W
Maximum opening time	20ms	
Terminal type	Flat	
Screw type	Phillips (N° 2)	
Tightening torque	1 N.m (8.8 lb.in)	0.8...1.2 N.m (7...10 lb.in)
Rigid cable	1 or 2 x (0.5...1.5 mm ²), 1 or 2 x (0.75...2.5 mm ²)	1 or 2 x (0.5...2.5 mm ² / 20...14 AWG)
Flexible cable	1 or 2 x (18...14 AWG)	1 (0.5...4 mm ² / 20...10 AWG) or 2 x (0.75...2.5 mm ² / 18...14 AWG)
Back-up fuses gL/gG	10 A	

Mounting configurations

Live or grounded parts distance to the circuit breaker				
Model	U_e	Minimum distance between the circuit breaker and live or grounded parts (mm)		
		B	C	A
MPW12/18	Up to 690 V	20	75	9
MPW40	Up to 500 V	30	95	9
	Up to 690 V	50	95	30
MPW80	Up to 690 V	50	150	10
MPW100	Up to 690 V	150	167	30

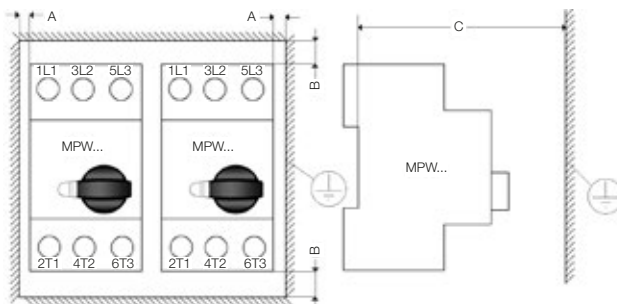

The motor protective circuit breaker can be mounted in any position, but according to IEC 60447 standard, the "On - I" indicator must be to the right or up.

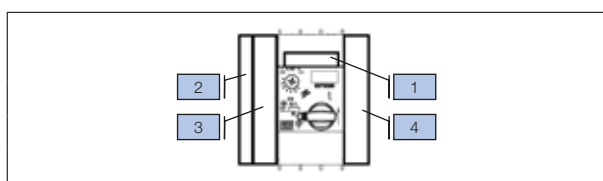

Allowed combinations of accessories			
ACBF (1)	ACBS (2)	TSB (3)	URMP or SRMP (4)
•	•	-	•
•	-	•	•
-	•	•	•

DC operation

The MPW12...MPW100 can also be used for operating continuous current loads. For such operation it is necessary to connect 2 or 3 poles in series.

See recommended circuits and their voltage limits in the table on the right.

Short-circuit breaking capacity $I_{cu} = 10$ kA for all configurations.

Circuits	Maximum direct current	Notes
	150 V _{dc}	System not grounded; 2 poles in series.
	300 V _{dc}	System grounded; 2 poles in series.
	450 V _{dc}	System grounded; 3 poles in series.

Diagrams

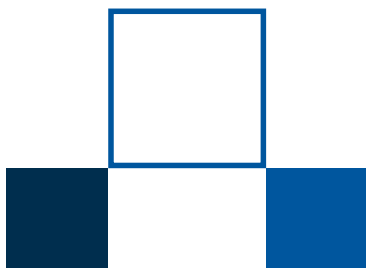
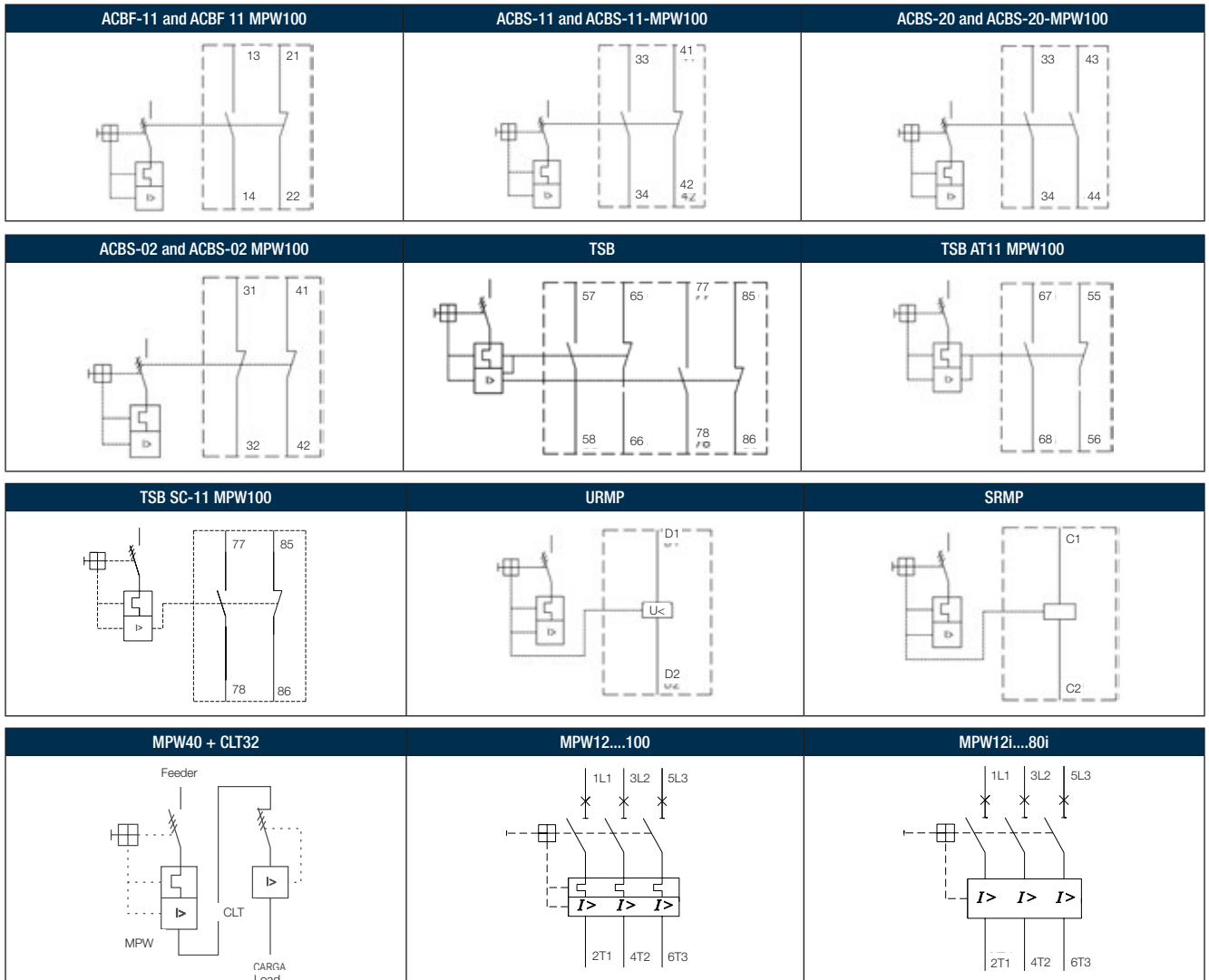

Breaking capacity (IEC 60947-2)

MPW12...100

Models	Maximum current (A)	220-230 V _{AC}			380-415 V _{AC}			440 V _{AC}			460-500 V _{AC}			630-690 V _{AC}		
		I _{CU}	I _{CS}	Max. fuse (gL/gG)	I _{CU}	I _{CS}	Max. fuse (gL/gG) ¹⁾	I _{CU}	I _{CS}	Max. fuse (gL/gG) ¹⁾	I _{CU}	I _{CS}	Max. fuse (gL/gG) ¹⁾	I _{CU}	I _{CS}	Max. fuse (gL/gG) ¹⁾
		kA	kA	A	kA	kA	A	kA	kA	A	kA	kA	A	kA	kA	A
MPW12/18	0.16	100	100	-	100	100	-	100	100	-	100	100	-	10	10	-
	0.25	100	100	-	100	100	-	100	100	-	100	100	-	10	10	-
	0.4	100	100	-	100	100	-	100	100	-	100	100	-	10	10	-
	0.63	100	100	-	100	100	-	100	100	-	100	100	-	10	10	-
	1	100	100	-	100	100	-	100	100	-	100	100	-	10	10	-
	1.6	100	100	-	100	100	-	100	100	-	100	100	-	10	10	-
	2.5	100	100	-	100	100	-	100	100	-	100	100	-	8	8	25
	4	100	100	-	100	100	-	100	100	-	100	100	-	8	8	35
	6.3	100	100	-	100	100	-	100	100	-	100	100	-	8	8	50
	10	100	100	-	50	10	100	50	10	80	10	10	63	5	5	50
	12 ²⁾	100	100	-	10	10	100	10	10	80	10	8	80	4	3	63
16	100	100	-	10	10	100	10	10	80	10	8	80	4	3	63	
18	100	100	-	10	10	100	10	10	80	10	8	80	4	3	63	
MPW40	0.16	100	100	-	100	100	-	100	100	-	100	100	-	100	100	-
	0.25	100	100	-	100	100	-	100	100	-	100	100	-	100	100	-
	0.4	100	100	-	100	100	-	100	100	-	100	100	-	100	100	-
	0.63	100	100	-	100	100	-	100	100	-	100	100	-	100	100	-
	1	100	100	-	100	100	-	100	100	-	100	100	-	100	100	-
	1.6	100	100	-	100	100	-	100	100	-	100	100	-	100	100	-
	2.5	100	100	-	100	100	-	100	100	-	100	100	-	8	8	25
	4	100	100	-	100	100	-	100	100	-	100	100	-	8	8	35
	6.3	100	100	-	100	100	-	100	100	-	100	100	-	8	8	50
	10	100	100	-	100	100	-	50	25	80	42	21	63	8	8	50
	16	100	100	-	50	25	100	50	15	80	10	8	80	5	5	63
	20	100	100	-	50	25	125	50	15	80	10	8	80	5	5	63
	25	100	100	-	50	25	125	50	15	100	10	8	80	5	5	80
32	100	100	-	50	25	125	25	15	100	10	8	100	5	5	100	
40	100	100	-	30	15	125	20	10	125	10	5	125	5	2	125	
MPW80	40	100	100	-	65	65	160	65	65	125	35	35	125	8	8	125
	50	100	100	-	65	65	160	65	65	160	35	35	160	8	8	160
	65	100	100	-	65	65	200	65	65	200	35	35	200	8	8	200
	80	65	65	224	65 ^{3)/10⁴⁾}	25 ^{3)/10⁴⁾}	224	10	10	224	10	10	224	6	6	224
MPW100	75	100	100	-	75	50	-	50	38	200	12	9	160	6	6	125
	90	100	100	-	75	50	-	50	38	200	12	9	160	6	6	160
	100	100	100	-	75	50	-	50	38	200	12	9	160	6	6	160

Self-protected against short circuit up to 100 kA.

- No backup fuses required.
- 1) In cases where prospective short-circuit current > I_{CU}, backup fuses are required.
- 2) Available with spring terminal only.
- 3) U_e ≤ 380 V.
- 4) U_e = 400/415 V.

Breaking capacity (IEC 60947-2) limiter function

MPW40+CLT32

Model	Maximum current (A)	380-415 V _{AC}			440 V _{AC}			460-500 V _{AC}			630-690 V _{AC}		
		I _{cu}	I _{cs}	Max. fuse (gL/gG) ¹⁾	I _{cu}	I _{cs}	Max. fuse (gL/gG) ¹⁾	I _{cu}	I _{cs}	Max. fuse (gL/gG) ¹⁾	I _{cu}	I _{cs}	Max. fuse (gL/gG) ¹⁾
		kA	kA	A	kA	kA	A	kA	kA	A	kA	kA	A
MPW40 + CLT32	0.16	◆	◆	-	◆	◆	-	◆	◆	-	◆	◆	-
	0.25	◆	◆	-	◆	◆	-	◆	◆	-	◆	◆	-
	0.4	◆	◆	-	◆	◆	-	◆	◆	-	◆	◆	-
	0.63	◆	◆	-	◆	◆	-	◆	◆	-	◆	◆	-
	1	◆	◆	-	◆	◆	-	◆	◆	-	◆	◆	-
	1.6	◆	◆	-	◆	◆	-	◆	◆	-	◆	◆	-
	2.5	◆	◆	-	◆	◆	-	◆	◆	-	50	50	-
	4	◆	◆	-	◆	◆	-	◆	◆	-	50	50	-
	6.3	◆	◆	-	◆	◆	-	◆	◆	-	50	50	-
	10	◆	◆	-	100	100	-	100	100	-	50	50	-
	16	100	100	-	100	100	-	100	100	-	50	50	-
	20	100	100	-	100	100	-	100	100	-	50	50	-
25	100	100	-	100	100	-	100	100	-	10	10	-	
32	100	100	-	100	100	-	100	100	-	10	10	-	

MPW80+MPW80i

Model	Maximum current (A)	380-415 V _{AC}			440 V _{AC}			460-500 V _{AC}			630-690 V _{AC}		
		I _{cu}	I _{cs}	Max. fuse (gL/gG) ¹⁾	I _{cu}	I _{cs}	Max. fuse (gL/gG) ¹⁾	I _{cu}	I _{cs}	Max. fuse (gL/gG) ¹⁾	I _{cu}	I _{cs}	Max. fuse (gL/gG) ¹⁾
		kA	kA	A	kA	kA	A	kA	kA	A	kA	kA	A
MPW80 + MPW80i-3-U080	40	◆	◆	-	◆	◆	-	65	65	-	25	25	-
	50	◆	◆	-	◆	◆	-	65	65	-	25	25	-
	65	◆	◆	-	◆	◆	-	65	65	-	25	25	-
	80	◆	◆	-	◆	◆	-	80	80	-	25	25	-

Self-protected against short circuit up to 100 kA.

- No backup fuses required.
- 1) In cases where prospective short-circuit current > I_{cu}, backup fuses are required.
- ◆ Not applicable as the MPW40 and MPW80 motor protective circuit breakers already have 100 kA I_{cu} / I_{cs} in related ranges.

Characteristic curves

The tripping characteristic shows the motor circuit breaker trip time in relation to the rated current. The curves show average tolerance range values for an ambient temperature of 20 °C, starting in cold state.

Thermal trip time when working in operating temperature is reduced to around 25% of the presented values. Under normal operating conditions, all 3 circuit breaker phases must be conducting.

MPW12...80

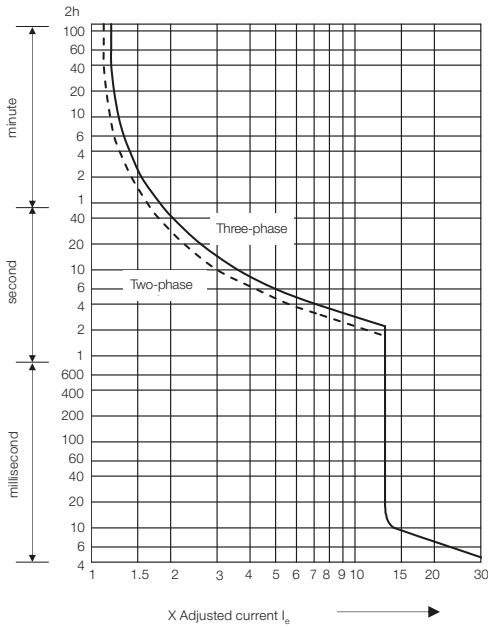

MPW40t

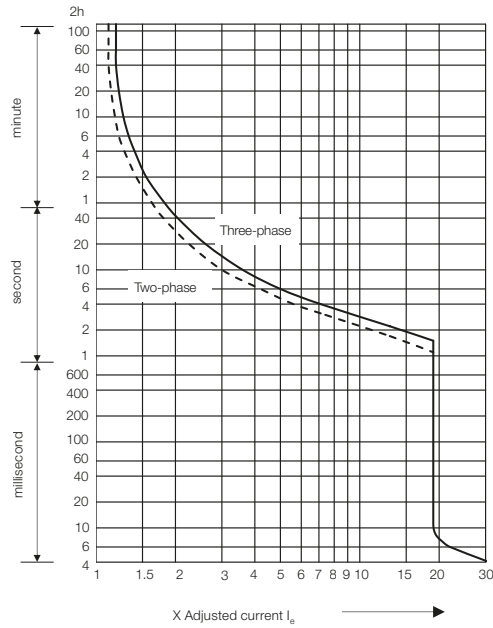

MPW12i...80i

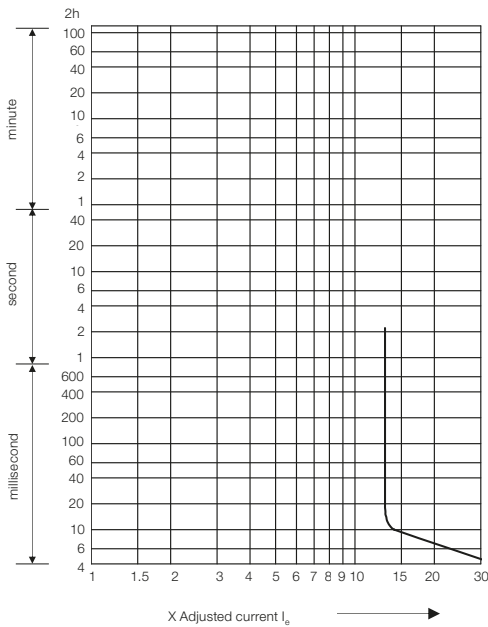

MPW100

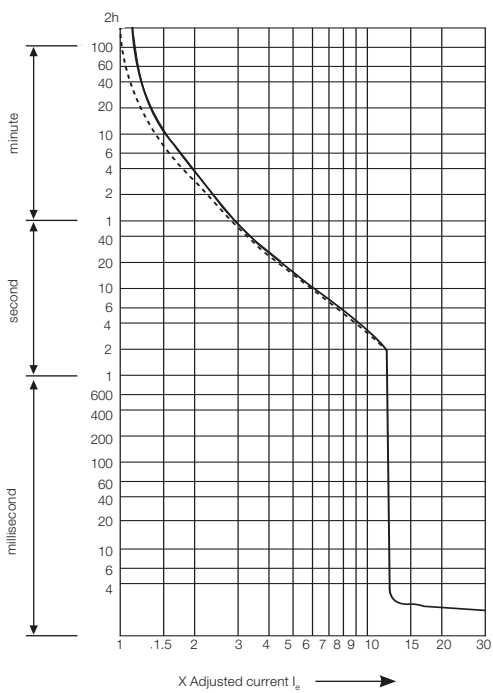

Characteristic curves

I²t at 415 V - MPW12/18 and MPW18i

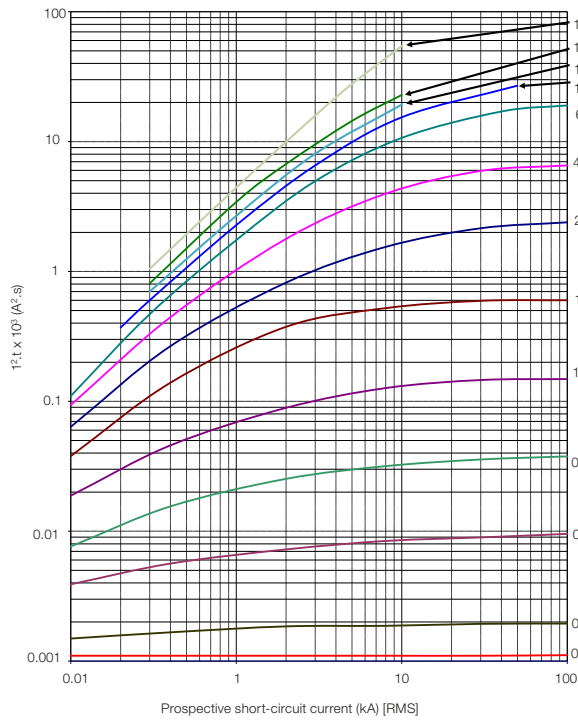

I²t at 415 V - MPW40 and MPW40i

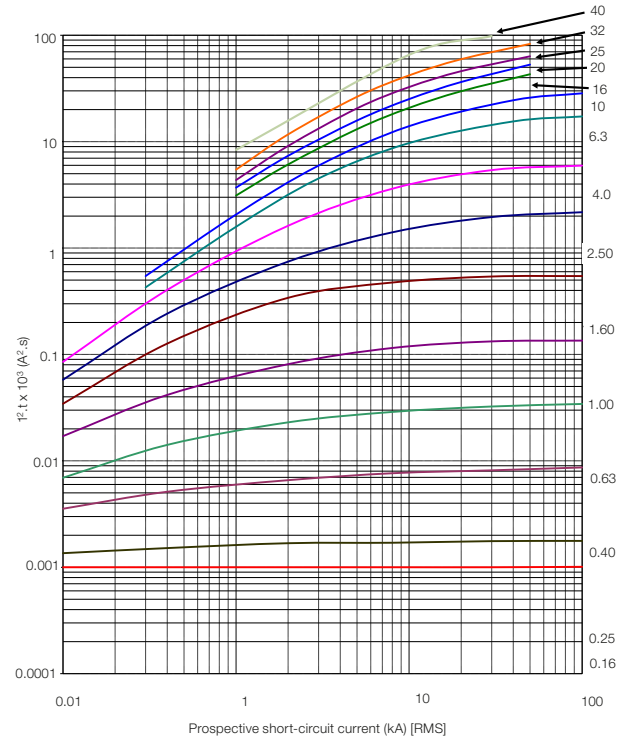

I²t at 415 V - MPW80

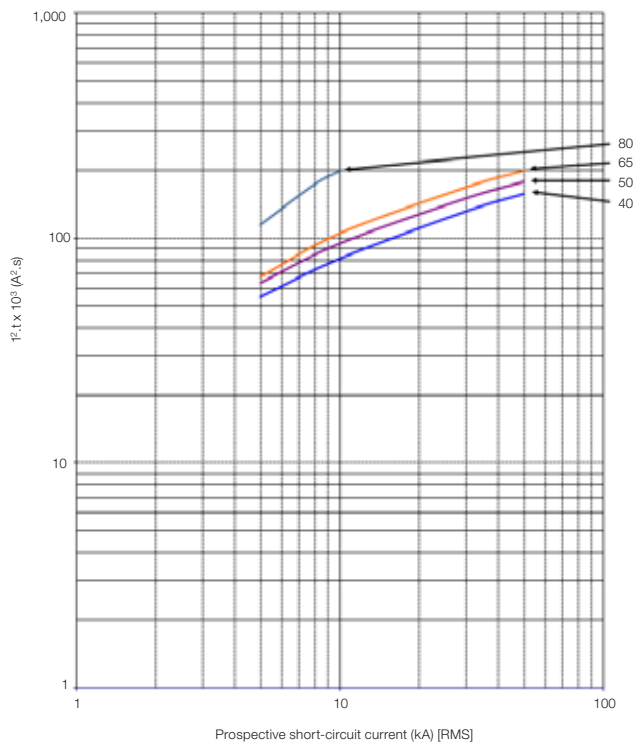

Note: MPW100 on request.

Characteristic curves

Short-circuit current limitation curve at 400/415 V - MPW40

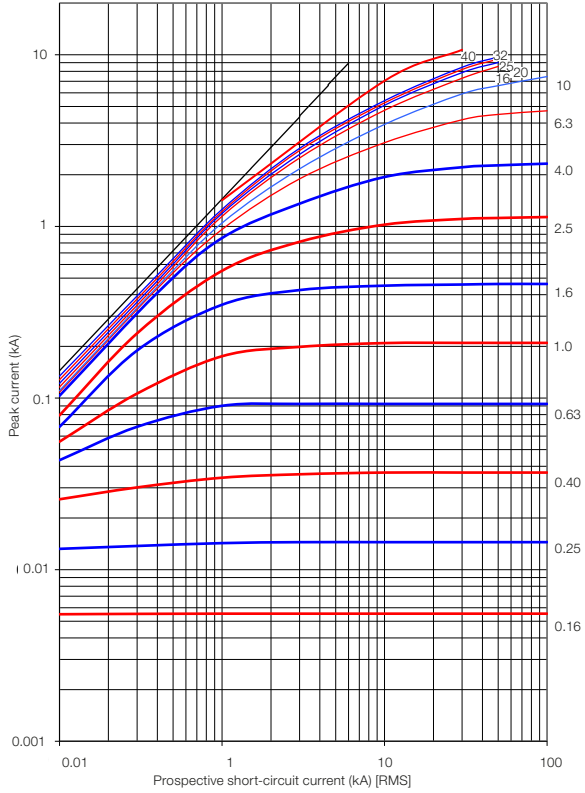

Short-circuit current limitation curve at 440 V - MPW40

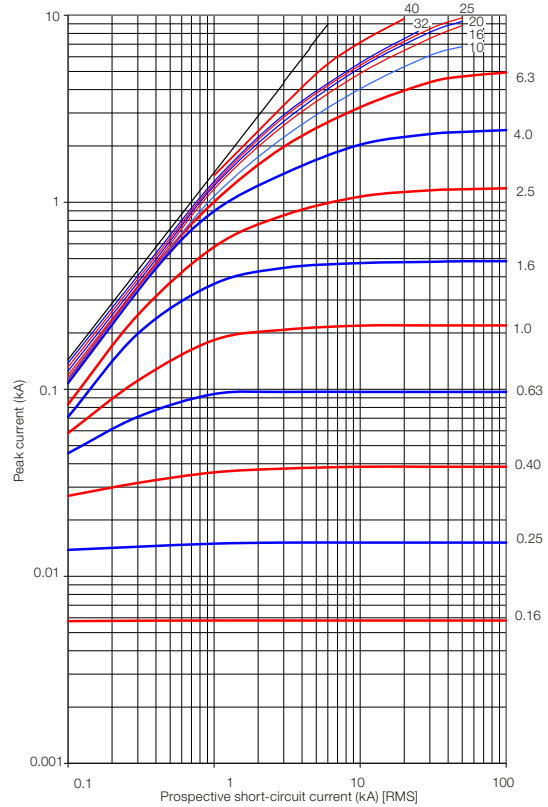

Short-circuit current limitation curve at 500 V - MPW40

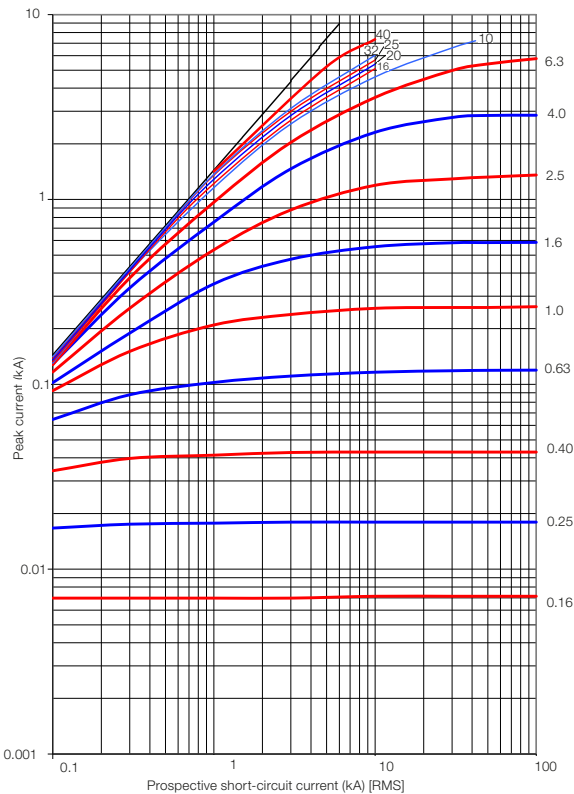

Typical circuits

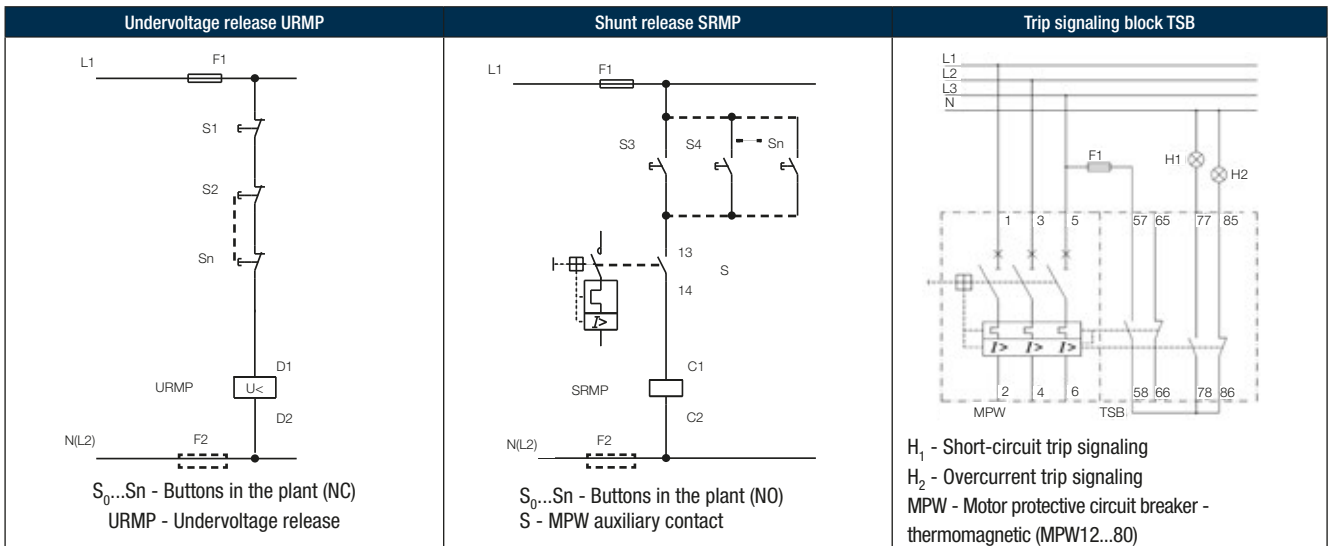
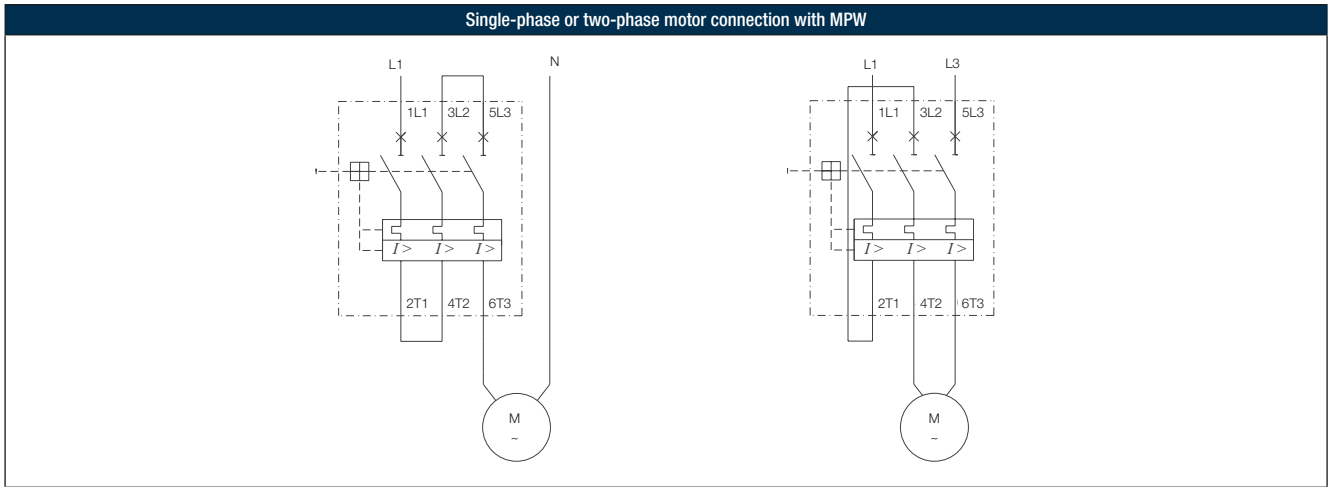

Dimensions (mm)

MPW12 + accessories - spring terminal

Mounting position

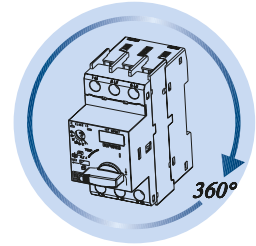
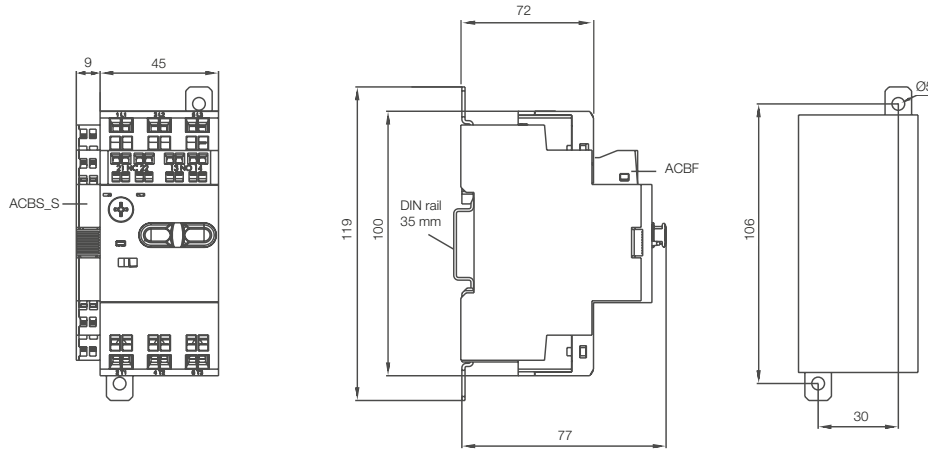

MPW18 + accessories - screw terminal

Mounting position

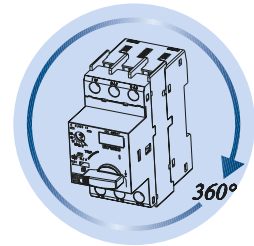
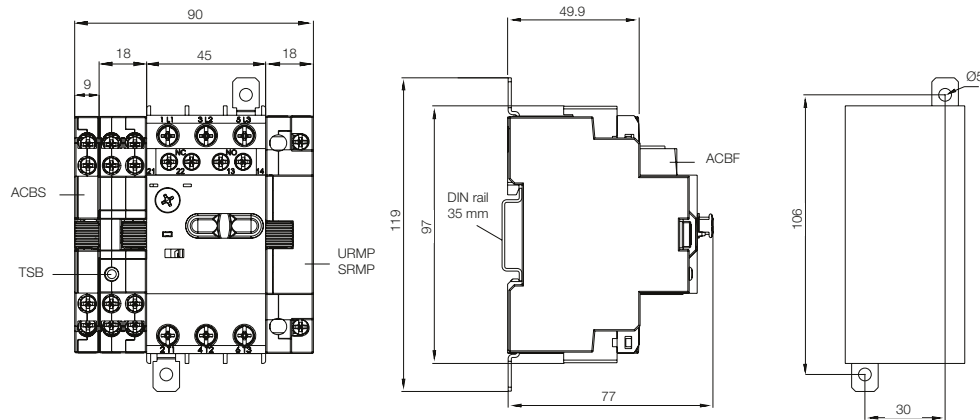

Dimensions (mm)

MPW18 + CWC07...16

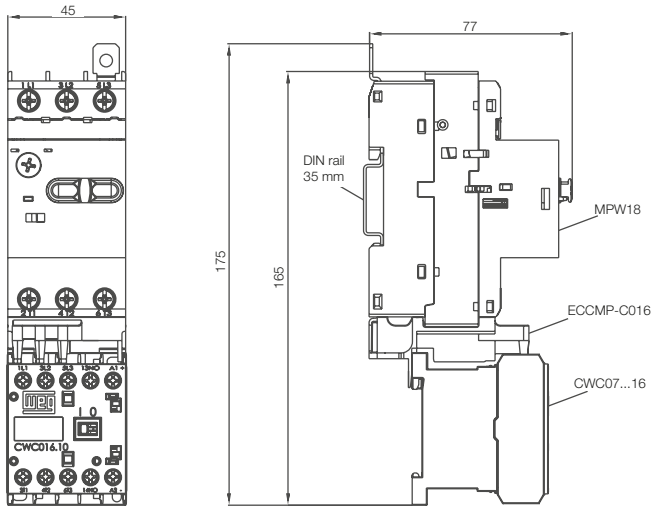

MPW18 + CWB9...38 (AC coil)

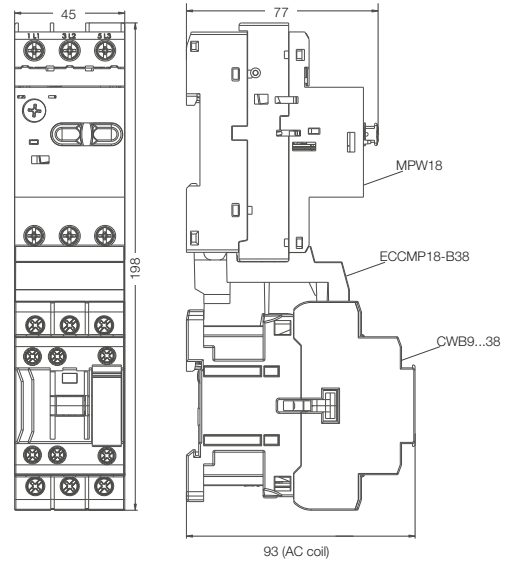

Insulated enclosures PE41/66

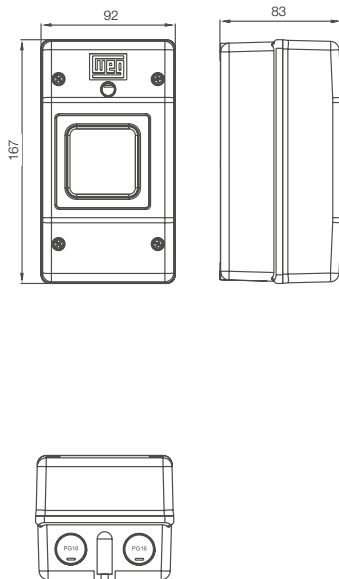

Insulated enclosures PE41/66 + emergency stop buttons

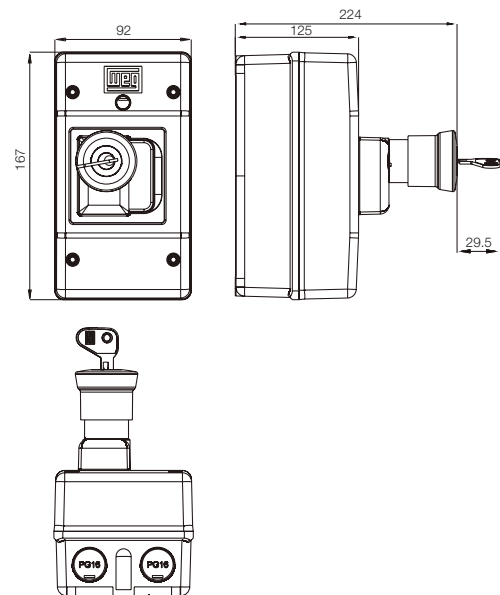

Dimensions (mm)

MPW40 + accessories

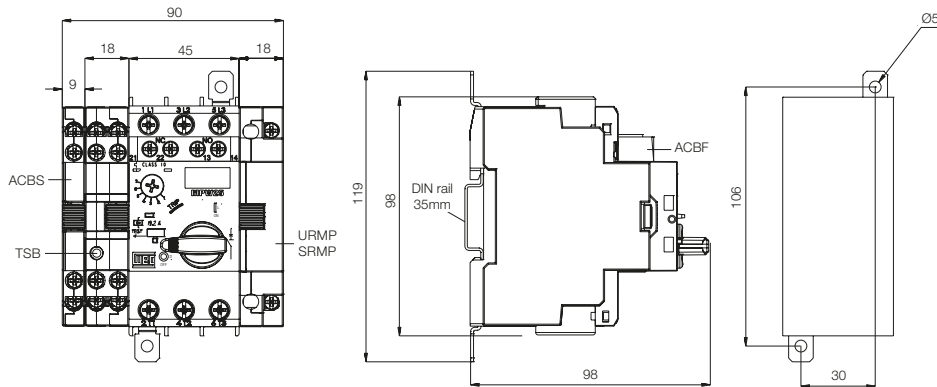

Mounting position

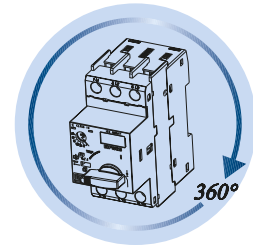

MPW40 + CW07

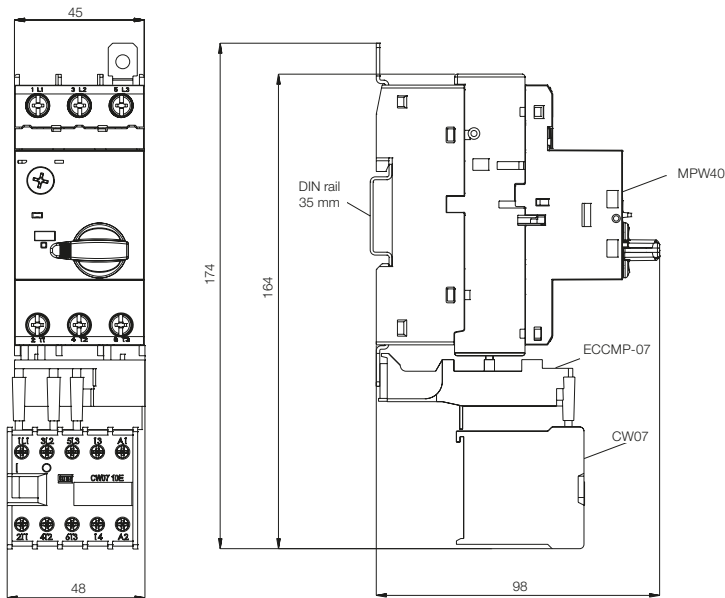

MPW40 + CWC07..16

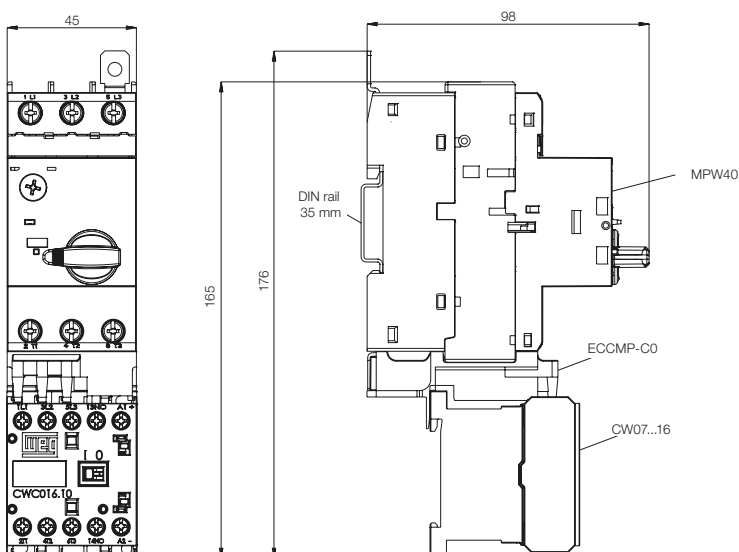

Dimensions (mm)

MPW40 + CWC025

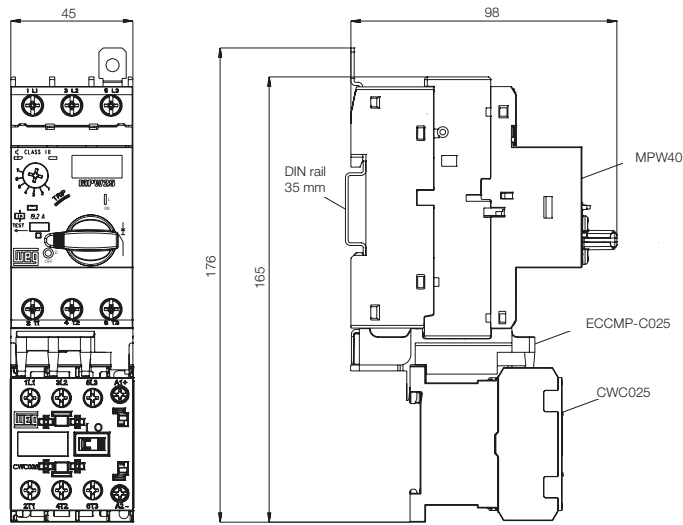

MPW40 + CWM9...18

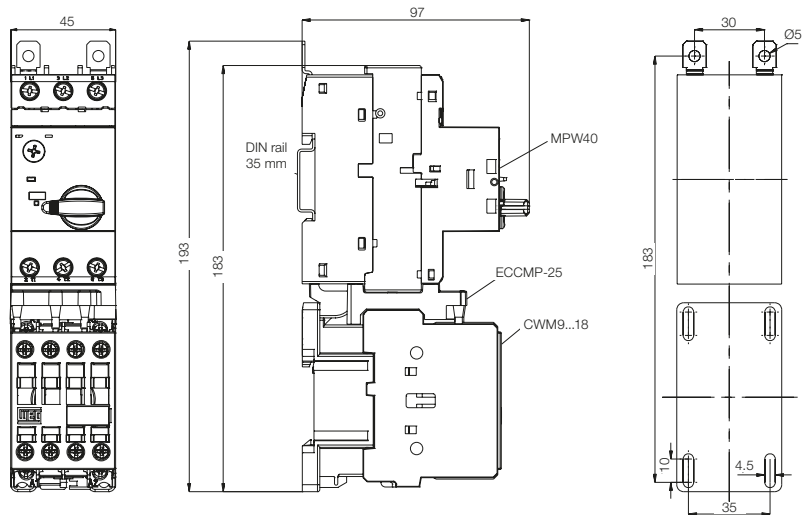

MPW40 + CWM25

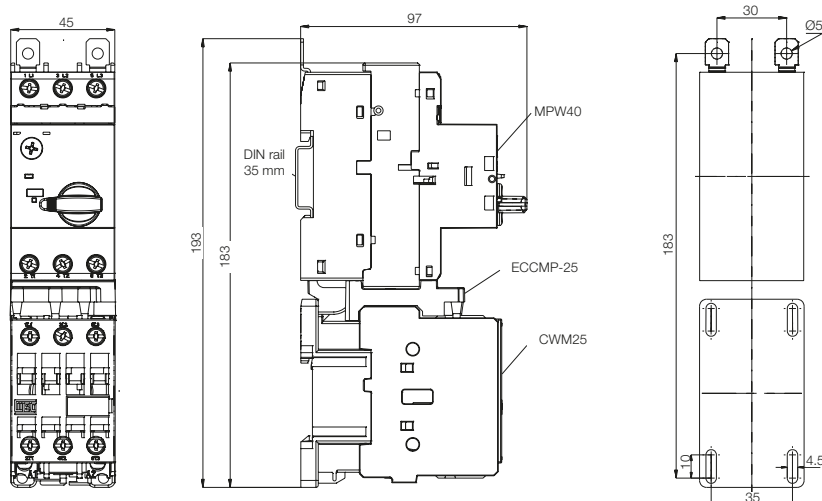

Dimensions (mm)

MPW40 + CWM32/40

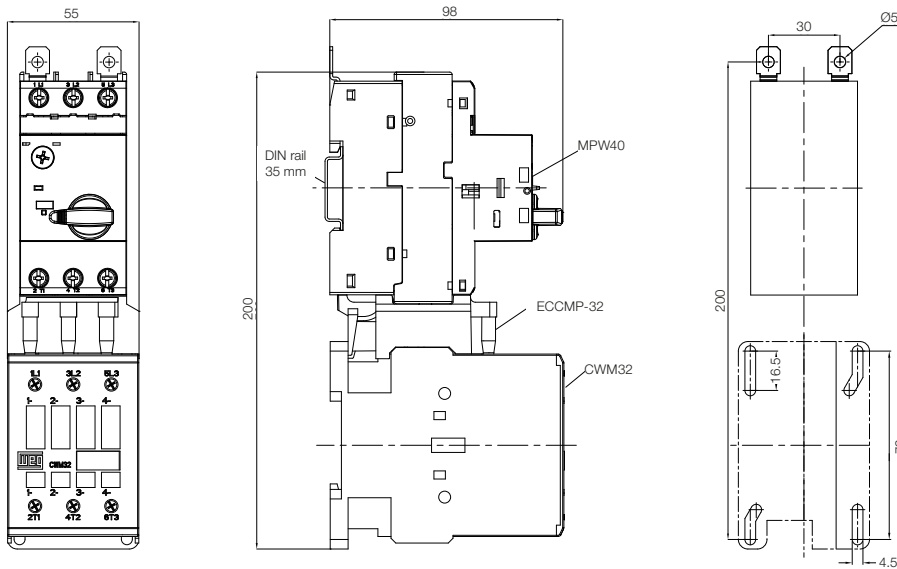

MPW40 + CWB9...38

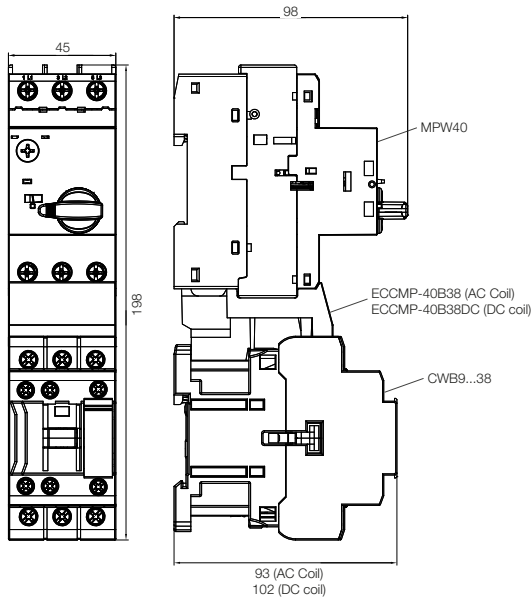

Current limiter - CLT32

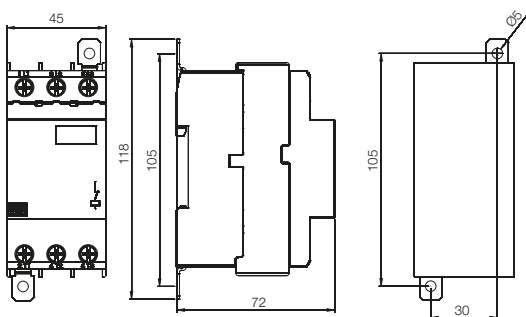

Dimensions (mm)

MPW80

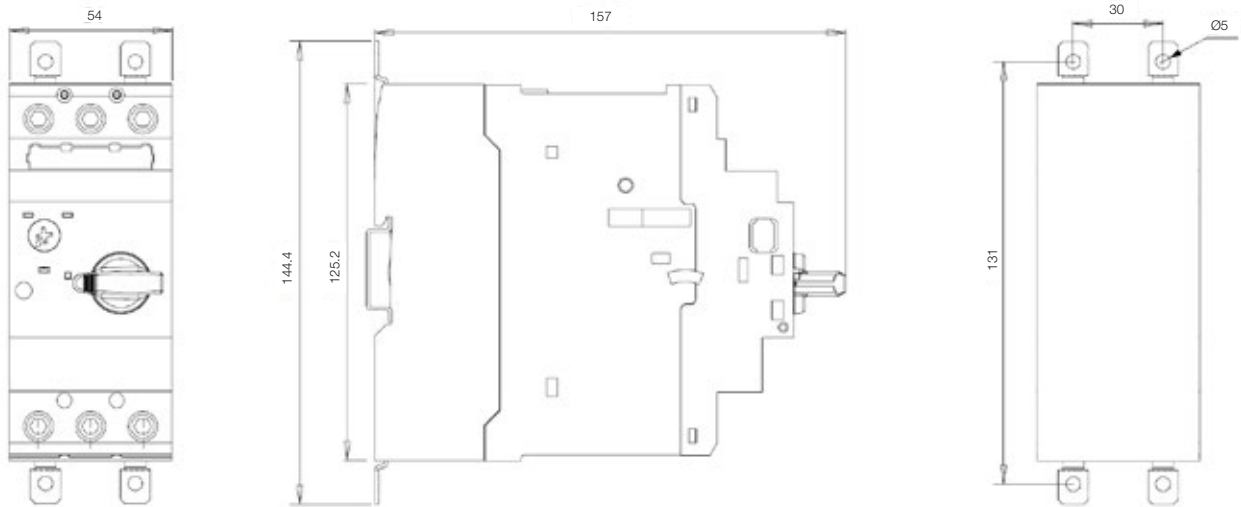

MPW80 + CWB40...80

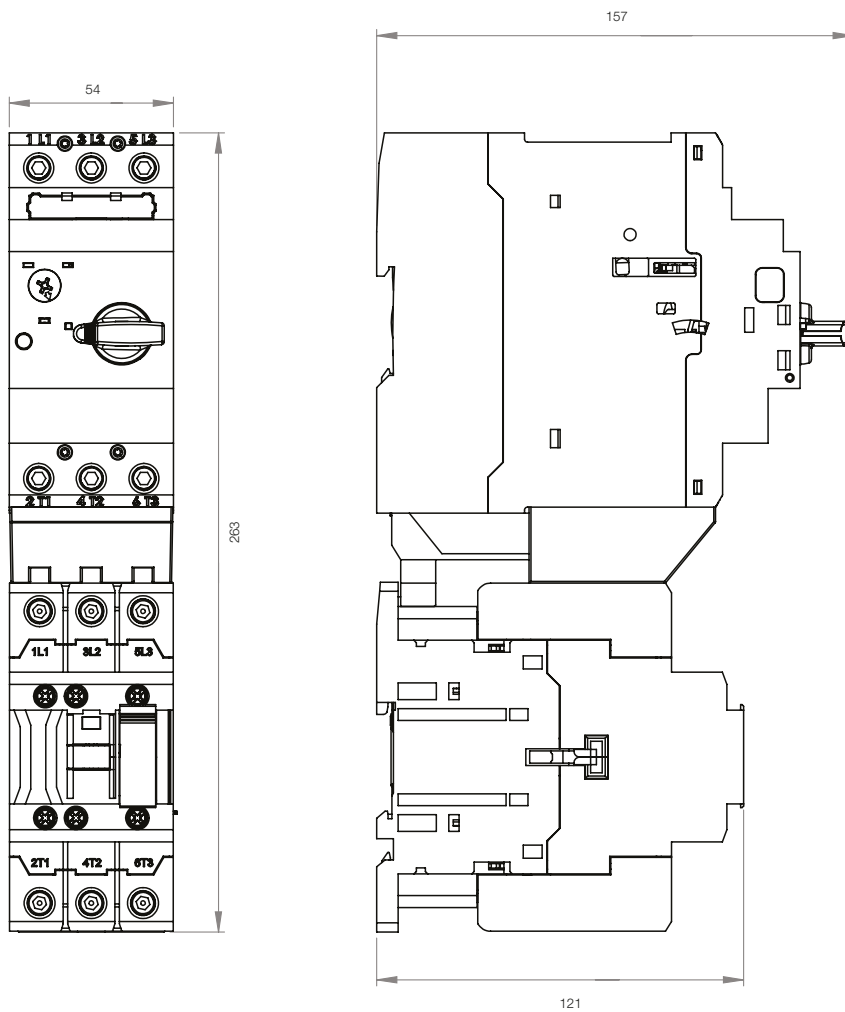

Dimensions (mm)

Front plate - FME55

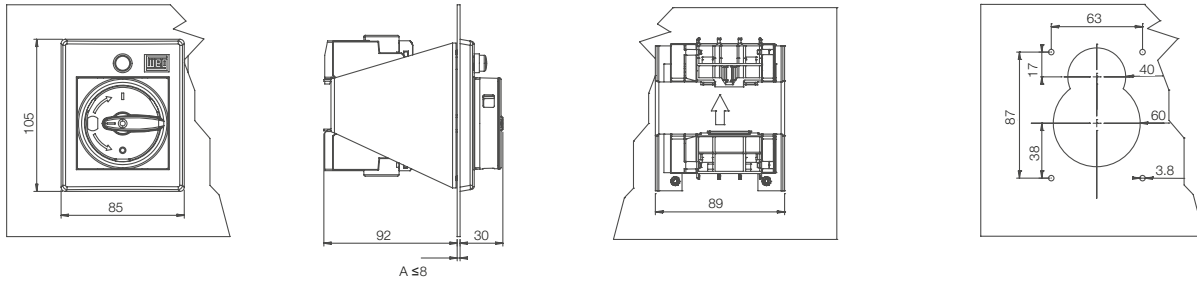

Insulated enclosure - PE55

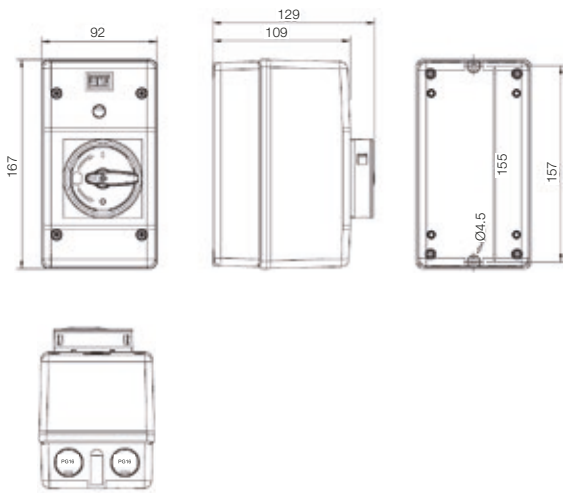

Insulated enclosure - LPE55

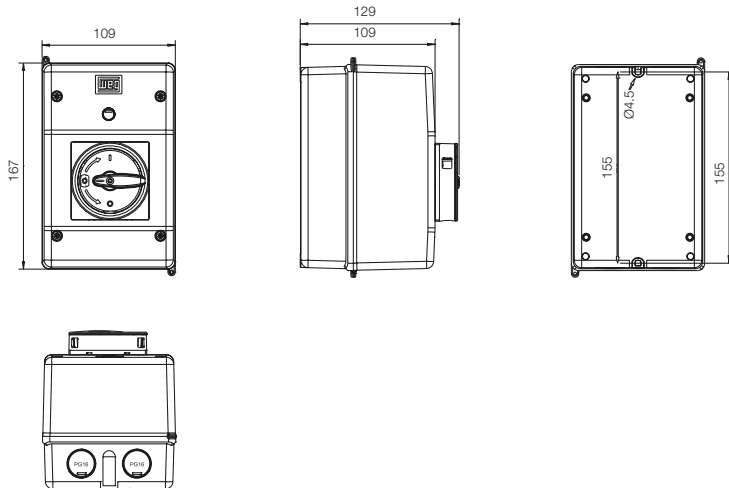

Dimensions (mm)

BBS45, BBS54, FTBBS, CSD

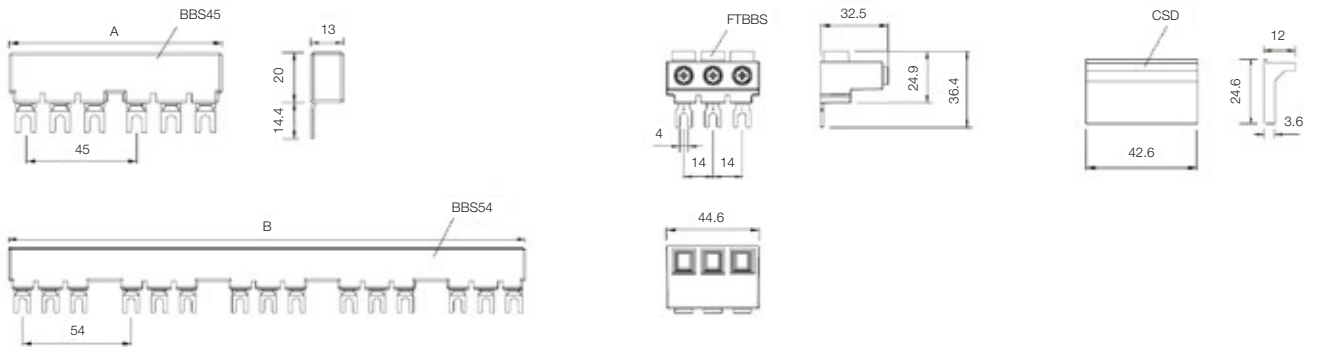

Model	BBS45-2	BBS45-3	BBS45-4	BBS45-5
A	85	130	175	220
Model	BBS54-2	BBS54-3	BBS54-4	BBS54-5
B	94	149	202	256

LST25

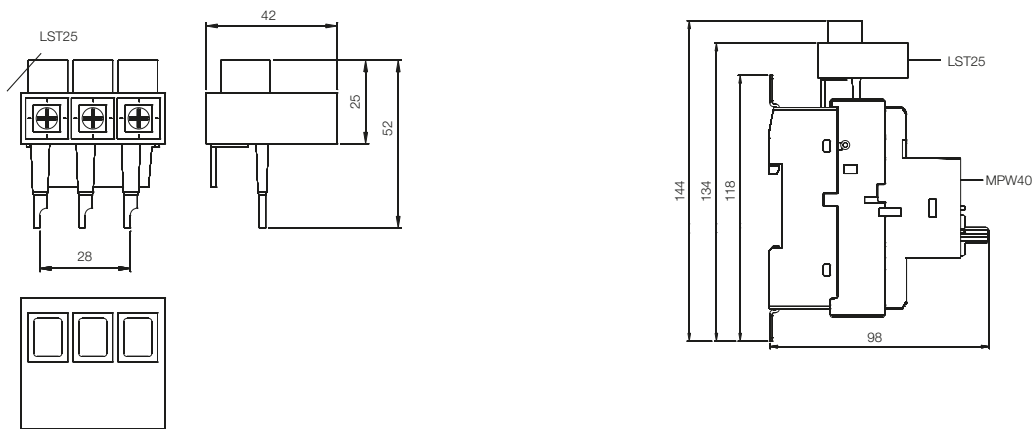

LST65

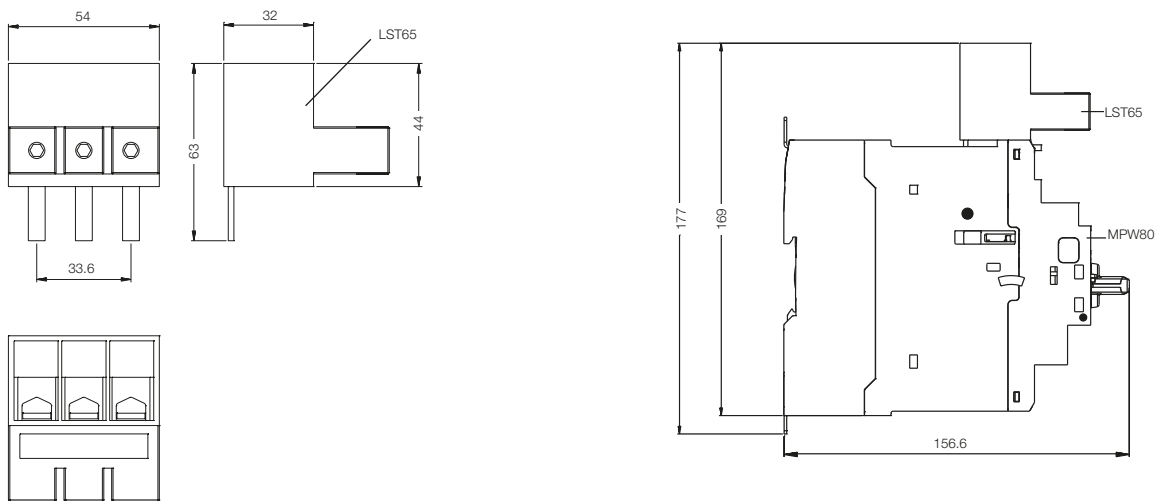

Dimensions (mm)

Door coupling rotary handle - RMMP

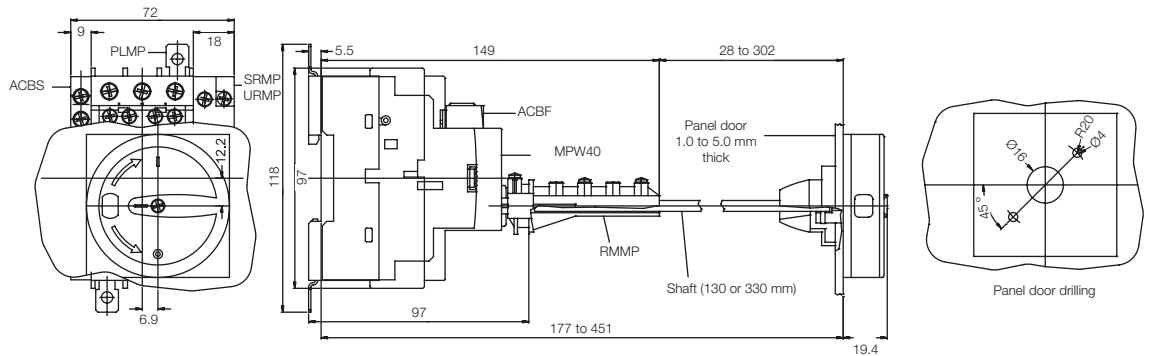

Door coupling rotary handle - MRX

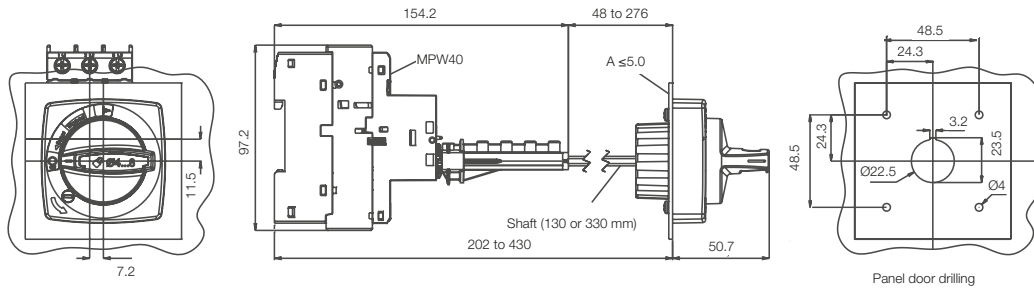

MPW80 + accessories

Mounting position

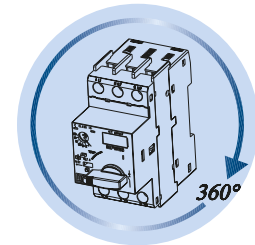
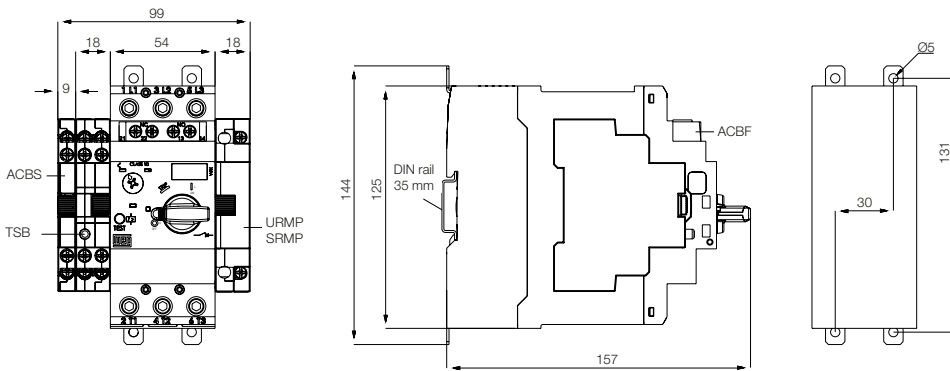

Dimensions (mm)

Door coupling rotary handle - RMMP65

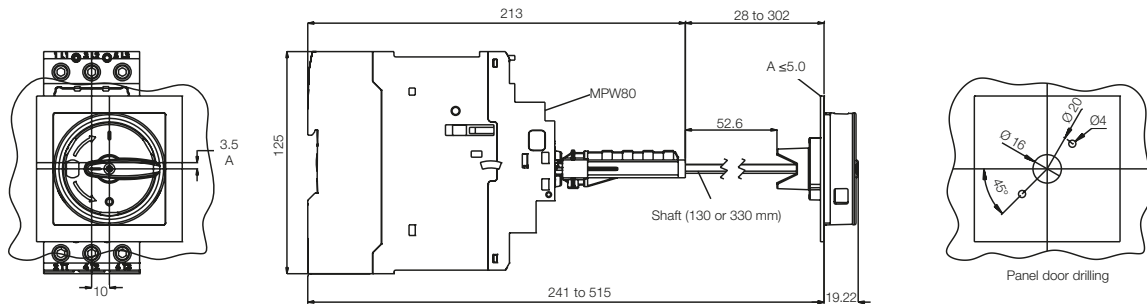

Door coupling rotary handle - MRX65

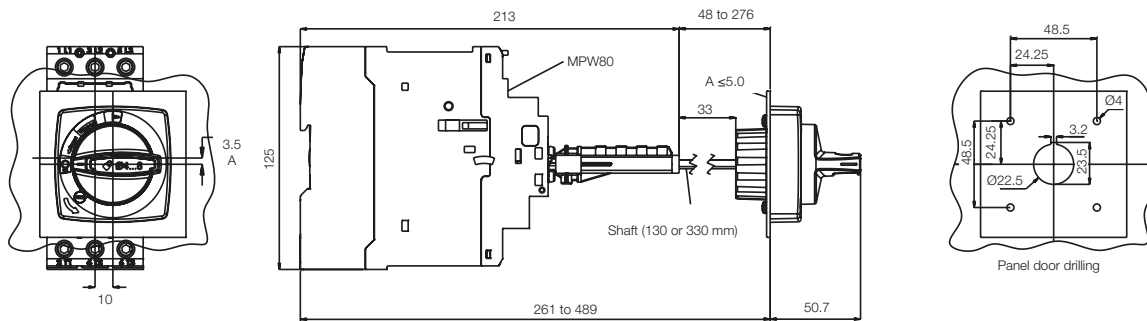

MPW100 + accessories

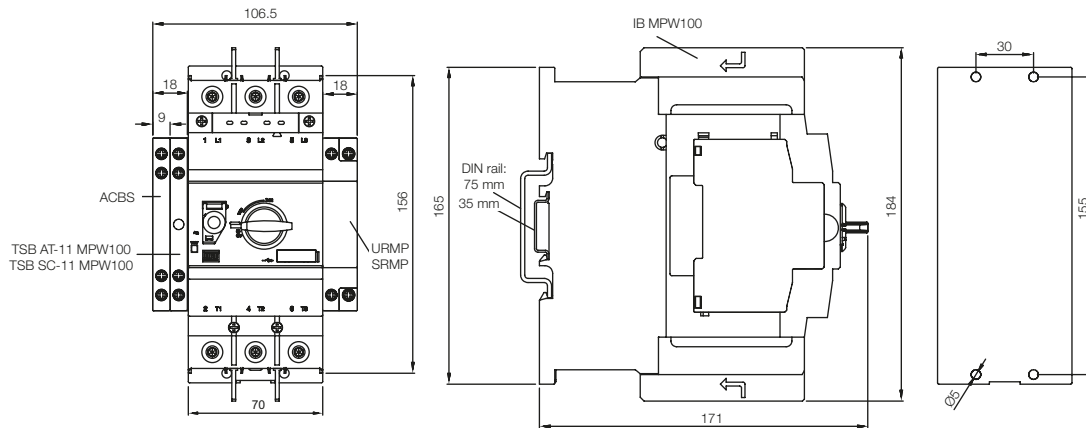

Dimensions (mm)

Door coupling rotary handle - MR MPW100

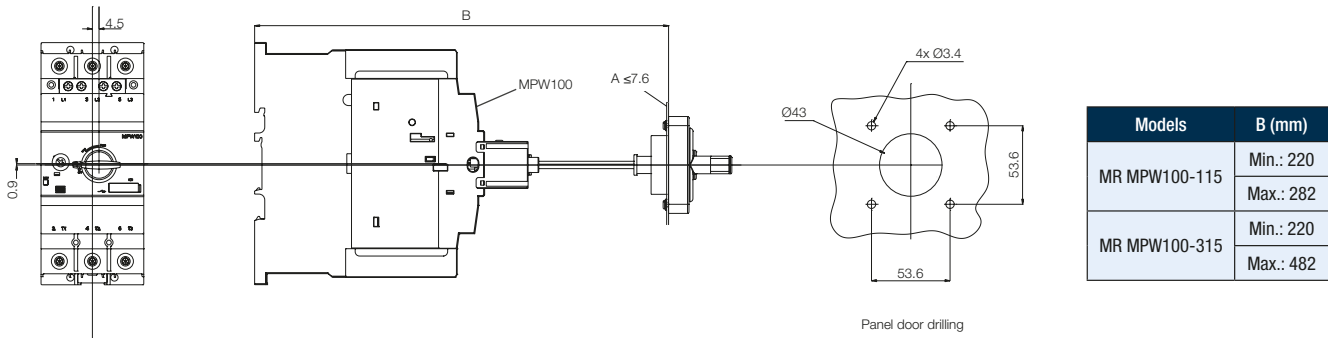

Door coupling rotary handle - MRX100

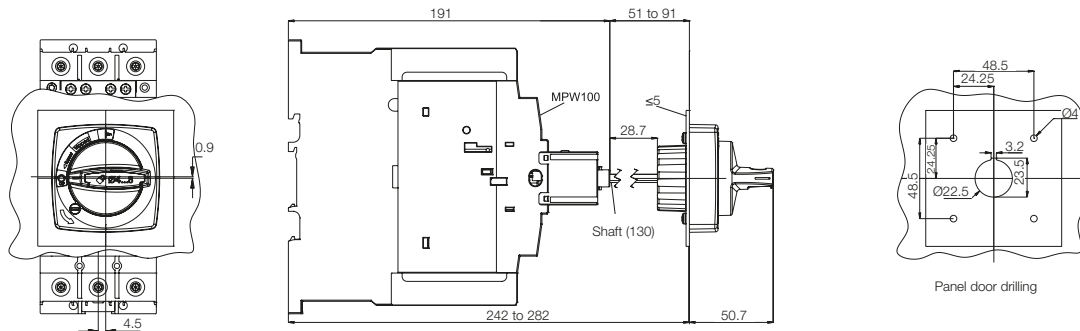

Mounting position

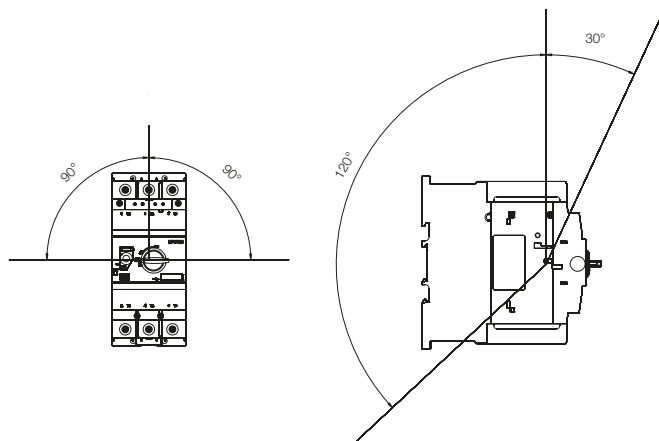

Global presence

is essential, as much as understanding your needs.

Global Presence

With more than 40,000 employees worldwide, WEG is one of the largest electric motors, electronic equipments and systems manufacturers. We are constantly expanding our portfolio of products and services with expertise and market knowledge. We create integrated and customized solutions ranging from innovative products to complete after-sales service.

WEG's know-how guarantees our **MPW motor protective circuit breakers** are the right choice for your application and business, assuring safety, efficiency and reliability.



Availability is to have a global support network



Partnership is to create solutions that suits your needs



Competitive edge is to unite technology and innovation

Know More

High performance and reliable products to improve your production process.

Excellence is to provide a whole solution in industrial automation that improves our customers productivity.

Visit:

www.weg.net



[youtube.com/wegvideos](https://www.youtube.com/wegvideos)



The scope of WEG Group solutions is not limited to products and solutions presented in this catalogue.

To see our portfolio, contact us.

For WEG's worldwide operations visit our website



www.weg.net



 +55 47 3276.4000

 automacao@weg.net

 Jaraguá do Sul - SC - Brazil

Cod: 50053062 | Rev: 04 | Date (m/y): 02/2024.

The values shown are subject to change without prior notice.
The information contained is reference values.