

Inductive sensor
For high pressures
BI2-CRS730-AP4X2-H1141/S34

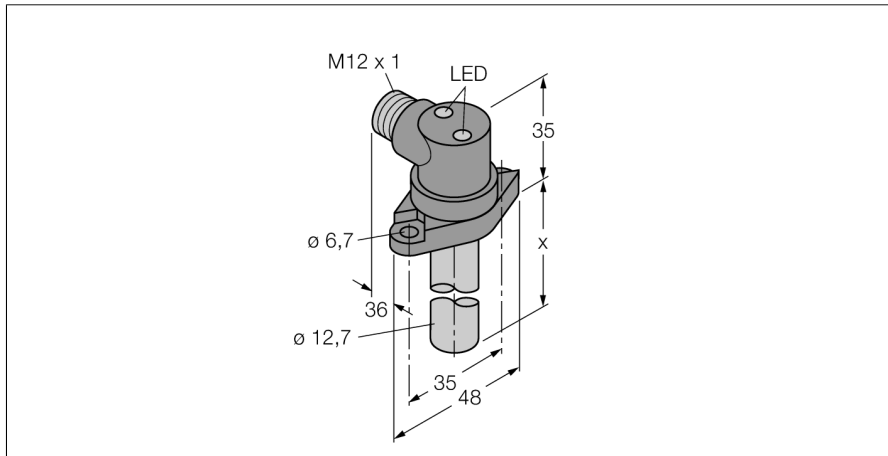

- Smooth barrel, stainless steel, 1.4305
- Ø 12.7 mm
- Housing, GD-Zn, chromated
- Admissible pressure static/dynamic 200/100 bar
- Magnetic field immune (insensitive to magnetic DC and AC fields)
- DC 3-wire, 10...65 VDC
- NO contact, PNP output
- M12 x 1 male connector

Wiring Diagram

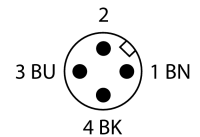
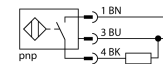

Functional principle

Inductive sensors detect metal objects contactless and wear-free. For this purpose they use a high-frequency electromagnetic AC field that interacts with the target. The sensors hosting a ferrite core coil generate the AC field through an LC resonant circuit.

Pressure-resistant inductive sensors withstand high pressures which makes them perfectly suited for position control in hydraulic cylinders.

Type designation	BI2-CRS730-AP4X2-H1141/S34
Ident-No.	4580003
Ident-No (TUSA)	T4580003
Rated switching distance Sn	2 mm
Mounting conditions	flush
Assured switching distance	≤ (0,81 x Sn) mm
Correction factors	St37 = 1; Al = 0.3; stainless steel = 0.7; Ms = 0.4
Repeatability	≤ 2 % of full scale
Static pressure	≤ 200 bar
Dynamic pressure	≤ 100 bar
Admissible contact medium	electrically conductive
Temperature drift	≤ ± 10 %
Hysteresis	3...15 %
Ambient temperature	-25...+70 °C
Operating voltage	10... 65VDC
Residual ripple	≤ 10 % U _s
DC rated operational current	≤ 200 mA
No-load current I ₀	≤ 15 mA
Residual current	≤ 0.1 mA
Rated insulation voltage	≤ 0.5 kV
Short-circuit protection	yes/ cyclic
Voltage drop at I ₀	≤ 1.8 V
Wire breakage / Reverse polarity protection	yes/ complete
Output function	3-wire, NO contact, PNP
Switching frequency	0.03 kHz
Construction	Smooth barrel, 12.7 mm
Probe length	73 mm, probe length x
Housing material	Metal, 1.4305 (AISI303)
Active area material	Plastic, PA12-GF30
Connector housing	metal, GdZn, chromated
Electrical connection	Flange connector, M12 x 1
Vibration resistance	55 Hz (1 mm)
Shock resistance	30 g (11 ms)
Protection class	IP67
Power-on indication	LED green
Switching state	LED red

Inductive sensor
For high pressures
BI2-CRS730-AP4X2-H1141/S34

Distance D	2 x B
Distance W	3 x Sn
Distance T	3 x B
Distance S	1.5 x B
Distance G	6 x Sn

Diameter of the active area B \varnothing 12.7 mm

