

# Inductive sensor

## BI1.5-EG08-AD6X-H1341

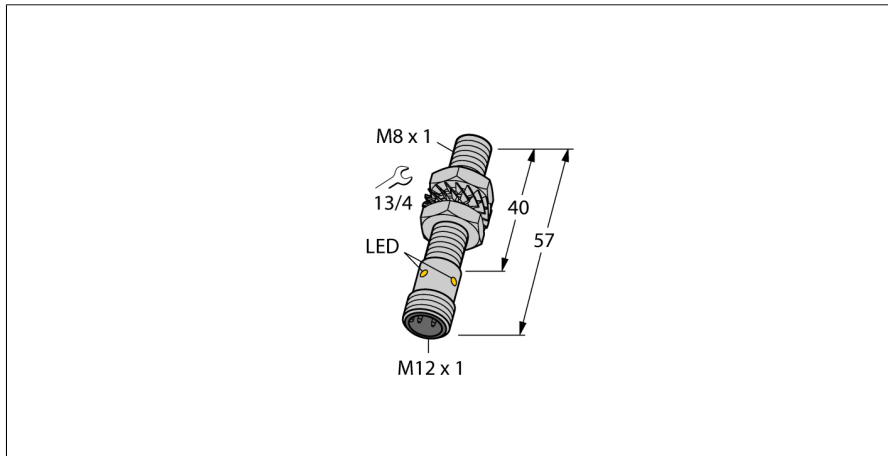

- Threaded barrel, M8 x 1
- Stainless steel, 1.4427 SO
- DC 2-wire, 10...30 VDC
- NO contact
- M12 x 1 male connector

### Wiring Diagram

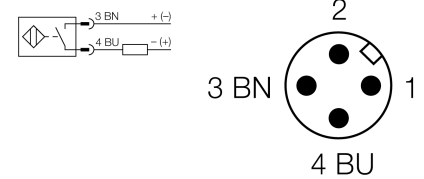

<b>Type designation</b>	BI1.5-EG08-AD6X-H1341
Ident-No.	4600203
Ident-No (TUSA)	S4600203
<b>Rated switching distance Sn</b>	1.5 mm
Mounting conditions	flush
Assured switching distance	$\leq (0,81 \times S_n)$ mm
Correction factors	St37 = 1; Al = 0.3; stainless steel = 0.7; Ms = 0.4
Repeatability	$\leq 2\%$ of full scale
Temperature drift	$\leq \pm 10\%$
Hysteresis	1...15 %
Ambient temperature	-25...+70 °C
<b>Operating voltage</b>	10... 30VDC
Residual ripple	$\leq 10\% U_{in}$
DC rated operational current	$\leq 100$ mA
Residual current	$\leq 0.6$ mA
Rated insulation voltage	$\leq 0.5$ kV
Short-circuit protection	yes/ cyclic
Voltage drop at $I_n$	$\leq 5$ V
Smallest operating current $I_m$	$\geq 3$ mA
Switching frequency	3 kHz
<b>Construction</b>	Threaded barrel, M8 x 1
Dimensions	57 mm
Housing material	Stainless steel, 1.4427 SO
Active area material	Plastic, PA12-GF30
Max. tightening torque housing nut	5 Nm
Electrical connection	Flange connector, M12 x 1
Vibration resistance	55 Hz (1 mm)
Shock resistance	30 g (11 ms)
Protection class	IP67
MTTF	2283 years acc. to SN 29500 (Ed. 99) 40 °C
<b>Switching state</b>	LED yellow

### Functional principle

Inductive sensors detect metal objects contactless and wear-free. For this, they use a high-frequency electromagnetic AC field that interacts with the target. Inductive sensors generate this field via an RLC circuit with a ferrite coil.

# Inductive sensor BI1.5-EG08-AD6X-H1341

**TURCK**  
*works*

Industrial  
Automation

---

Distance D	2 x B
Distance W	3 x Sn
Distance T	3 x B
Distance S	1.5 x B
Distance G	6 x Sn

---

Diameter of the active area B                     $\varnothing$  8 mm



**Inductive sensor  
BI1.5-EG08-AD6X-H1341**



**Accessories**

Type code	Ident-No.	Description	
QM-08	6945100	Quick-mount bracket with dead-stop, chrome-plated brass, male thread M12 x 1. Note: The switching distance of proximity switches may be reduced through the use of quick-mount brackets.	
BST-08B	6947210	Fixing clamp for threaded barrel devices, with dead-stop; material: PA6	
MW-08	6945008	Mounting bracket for threaded barrel devices; material: Stainless steel A2 1.4301 (AISI 304)	
BSS-08	6901322	Mounting bracket for smooth and threaded barrel devices; material: Polypropylene	
MBS80	69479	Mounting bracket for threaded barrel devices; material mounting block: Anodized aluminium	