

USER'S GUIDE

WFA SERIES ALUMINUM WALL FAN HEATER

REPLACEMENT COMPONENT LIST INCLUDED

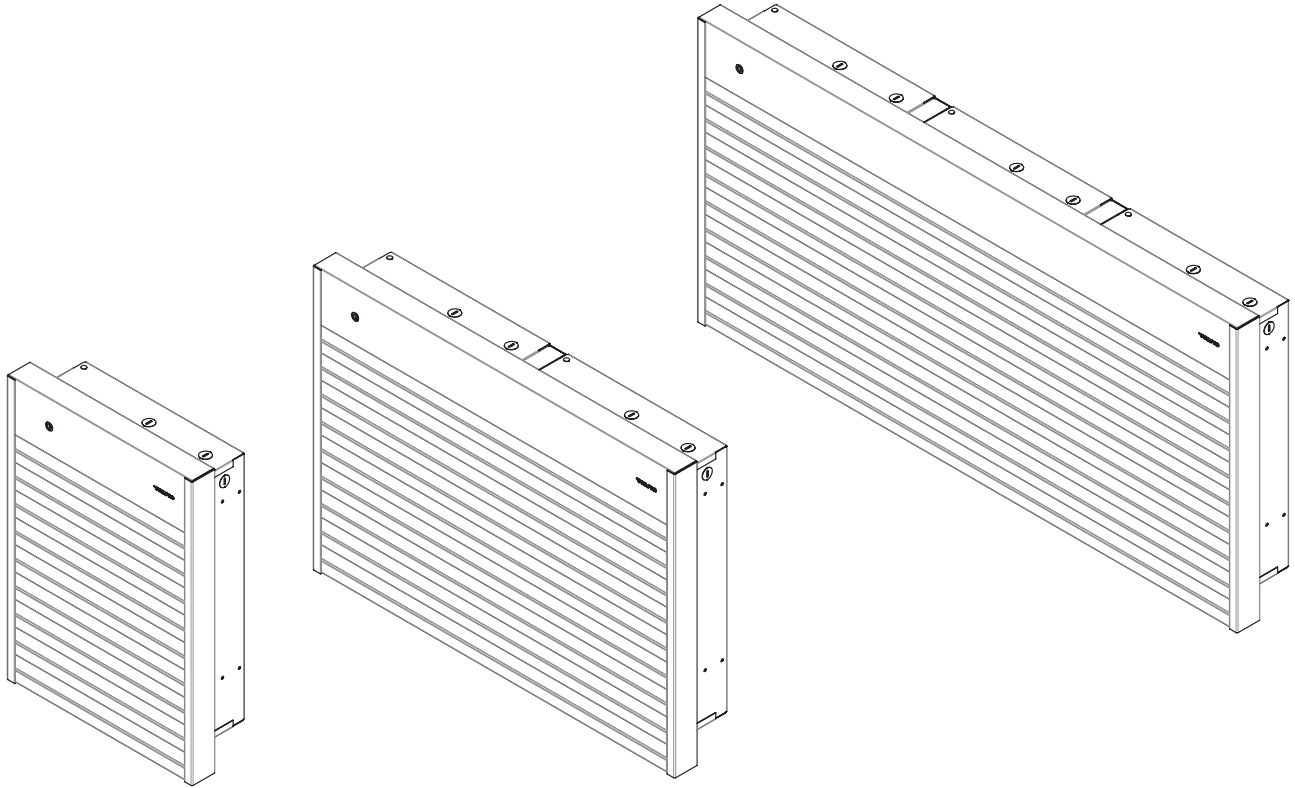

complies
with CSA
standards



WARNING

Before installing and operating this product, the user and/or installer must read, understand and follow these instructions and keep them handy for future reference. If these instructions are not followed, the warranty will be considered null and void and the manufacturer deems no further responsibility for this product.

This product must be installed by a qualified person and connected by a **certified electrician**, according to the **electrical and building codes** effective in your region.

The following instructions must be adhered to in order to avoid personal injuries or property damages, serious injuries and potentially fatal electric shocks.

Protect the heating unit with the appropriate circuit breaker or fuse, in accordance with the nameplate.

Make sure the line voltage (volt) is consistent with that indicated on the unit's nameplate.

This unit must be **grounded**.

Switch off the power at the circuit breaker/fuse before installing, repairing and cleaning the unit.

Make sure the unit is appropriate for the intended use (if needed, refer to the product catalog or a representative).

RECOMMENDED HEATING CAPACITY: 1.25 W/cubic foot (0.03 m³)

It corresponds to **10 W/square foot (0.09 m²)** based on a standard ceiling height of 8 feet (2.44 m). The recommended capacity is usually sufficient for normal heating needs. Please note that the insulation quality of walls and windows are some of the factors that influence heat losses, which modify the required capacity to heat a room. If needed, refer to a specialist (industrial and commercial buildings) who will be able to calculate these heat losses and optimize the required capacity or consult the "Online heating calculation" section of the Stelpro Design Web site (residential buildings). To heat a large room and to increase your comfort, it is recommended to install several units instead of one. For example, 2 X 1000 W rather than 1 X 2000 W.

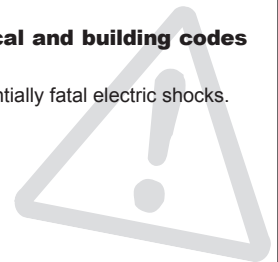



WARNING

Do not install the unit where objects or pieces of furniture could be heat damaged.

If the unit capacity is insufficient for the size of the room, it will be in operation continuously, and may become defective earlier and turn yellow.

Respect distances and positions indicated in the installation section.

If the installer or the user modifies the unit, he will be held responsible for any damage resulting from this modification, and the CSA certification could be void.

This unit must not come into contact with a water source and must be protected from splashes. Do not use it if any part has been immersed.

When mounting the unit, make sure that the anchorage used can support the total weight of the unit with the mounting brackets.

When cutting or drilling into a wall or a ceiling, do not damage electrical wiring and other hidden utilities.

When starting up the unit for the first time or after a long period, it is normal that it produces some temporary odours and whitish smoke.

Because this unit is hot when in use, it may pose risks even in normal operation. Therefore, be **careful and responsible** when using it. To avoid burns, do not let bare skin touch hot surfaces. The unit must cool down for few minutes since it will stay warm for some time after shut-down.

This unit must be installed at least **6 inches (15.2 cm)** from the walls and **8 inches (20.32 cm)** from the floor. However, make sure objects or pieces of furniture do not come into contact with the unit and keep them at least **24 inches (60 cm)** from the unit since they are more flammable than walls and floors. Failure to comply with this warning could lead to a fire. Some materials are more heat-sensitive than others, so make sure those near the unit can withstand heat.

Never block unit air vents. This obstruction could lead to overheating, which could result in a fire.

Do not insert or allow foreign objects to enter any air vent as this may cause electric shocks, fires, or damages to the unit.

This unit has hot and arcing or sparking parts inside. It is not designed to be used or stored in wet areas or areas containing flammable liquids, combustible materials or corrosive, abrasive, chemical, explosive and flammable substances such as, but not limited to, gasoline, paint, chlorine, sawdust and cleaning products.

Some areas are dustier than others. Thus, it is the user's responsibility to evaluate if the unit **must be cleaned** based on the amount of dirt accumulated on and inside air vents. Accumulated dirt can lead to a component malfunction or discoloration (yellow). It may cause a fire hazard if not installed and maintained in accordance with these instructions.

The thermal protection activation indicates that the unit has been subjected to abnormal operating conditions. If the thermal protection remains activated or activates and deactivates repeatedly, it is recommended that a qualified electrician or a certified repair centre examine the unit in order to make sure it is not damaged. (Refer to the limited warranty)

If the unit is damaged or defective, cut off power supply at circuit breaker and call a certified repair centre. (Refer to the limited warranty)

Make sure that all the electrical connections have been secured and made properly. Pull each wire to ensure it is not loose in the connector or the terminal board as this may cause a fire.

If an option must be added, make sure it has been approved by Stelpro. This way, it will ensure that it has been tested in accordance with our safety rules and that an appropriate installation has been planned into the unit.

Note: When a part of the product specification must be changed to improve operability or other functions, priority is given to the product specification itself. In such instances, the instruction manual may not entirely match all the functions of the actual product. Therefore, the actual product and packaging, as well as the name and illustration, may differ from the manual.

SPECIFICATIONS

WFA SERIES – WITHOUT CONTROL					
UNIT	TYPE	WATTS	VOLTS	KG	LB
SINGLE	WFA1502	1500	240	10	22
SINGLE	WFA2002	2000	240	10	22
SINGLE	WFA3002	3000	240	10	22
SINGLE	WFA4002	4000	240	10	22
SINGLE	WFA4802	4800	240	10	22
SINGLE	WFA1508	1500	208	10	22
SINGLE	WFA2008	2000	208	10	22
SINGLE	WFA3008	3000	208	10	22
SINGLE	WFA4008	4000	208	10	22
SINGLE	WFA4808	4800	208	10	22
SINGLE	WFA1507	1500	277	10	22
SINGLE	WFA2007	2000	277	10	22
SINGLE	WFA3007	3000	277	10	22
SINGLE	WFA4007	4000	277	10	22
SINGLE	WFA4807	4800	277	10	22
SINGLE	WFA1502T	1500	240	10	22
SINGLE	WFA2002T	2000	240	10	22
SINGLE	WFA3002T	3000	240	10	22
SINGLE	WFA4002T	4000	240	10	22
SINGLE	WFA4802T	4800	240	10	22
SINGLE	WFA1508T	1500	208	10	22
SINGLE	WFA2008T	2000	208	10	22
SINGLE	WFA3008T	3000	208	10	22

WFA SERIES – WITHOUT CONTROL					
UNIT	TYPE	WATTS	VOLTS	KG	LB
SINGLE	WFA4008T	4000	208	10	22
SINGLE	WFA4808T	4800	208	10	22
SINGLE	WFA1507T	1500	277	10	22
SINGLE	WFA2007T	2000	277	10	22
SINGLE	WFA3007T	3000	277	10	22
SINGLE	WFA4007T	4000	277	10	22
SINGLE	WFA4807T	4800	277	10	22
SINGLE	WFA1503T	1500	347	10	22
SINGLE	WFA2003T	2000	347	10	22
SINGLE	WFA3003T	3000	347	10	22
SINGLE	WFA4003T	4000	347	10	22
SINGLE	WFA4803T	4800	347	10	22
SINGLE	WFA1505T	1500	480	10	22
SINGLE	WFA2005T	2000	480	10	22
SINGLE	WFA3005T	3000	480	10	22
SINGLE	WFA4005T	4000	480	10	22
SINGLE	WFA4805T	4800	480	10	22
SINGLE	WFA1506T	1500	600	10	22
SINGLE	WFA2006T	2000	600	10	22
SINGLE	WFA3006T	3000	600	10	22
SINGLE	WFA4006T	4000	600	10	22
SINGLE	WFA4806T	4800	600	10	22

Several other models with control are available in higher voltages and wattages.

For a complete model list, consult our online product catalog at www.stelpro.com

TECHNICAL DRAWINGS

SINGLE UNIT

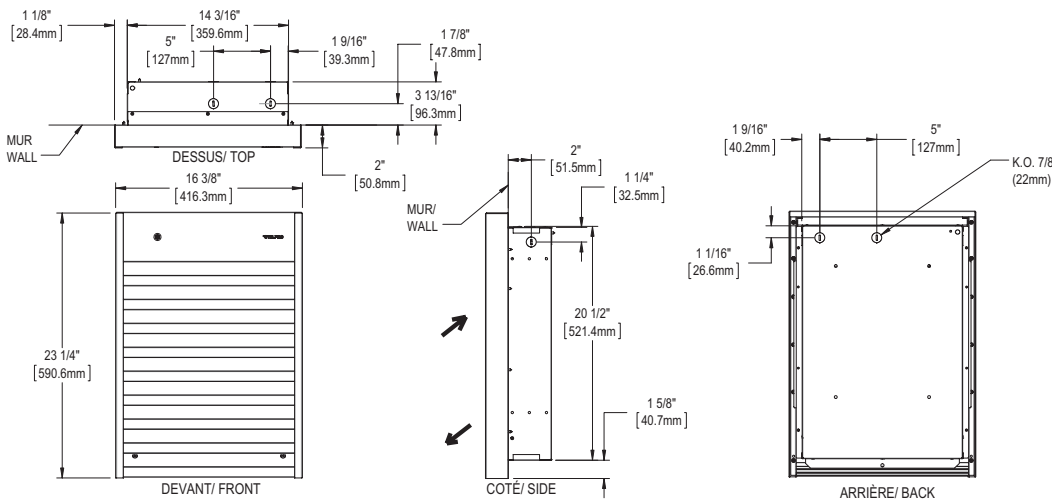

DOUBLE UNIT

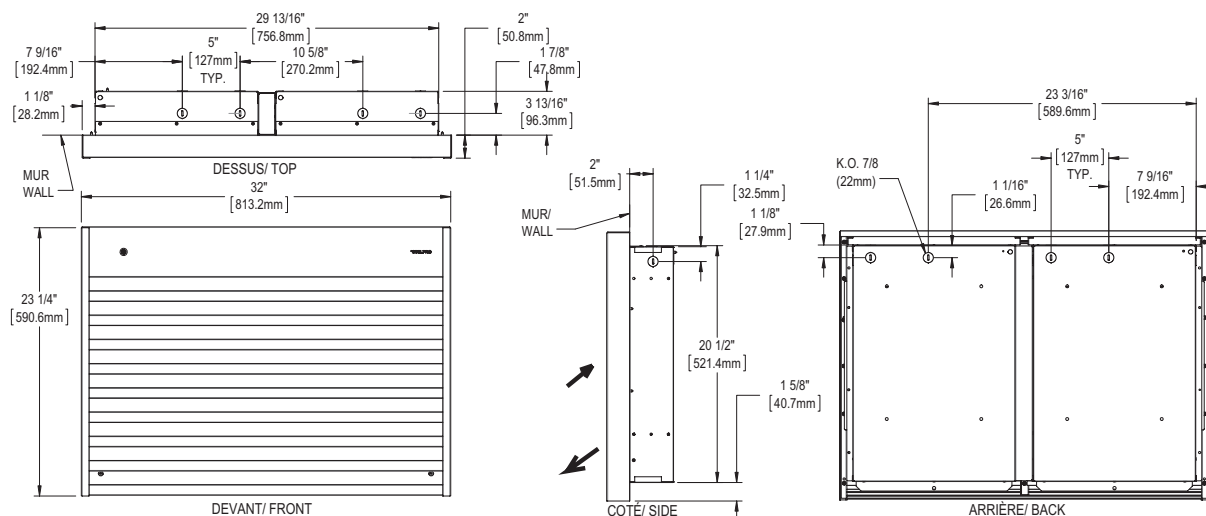

TRIPLE UNIT

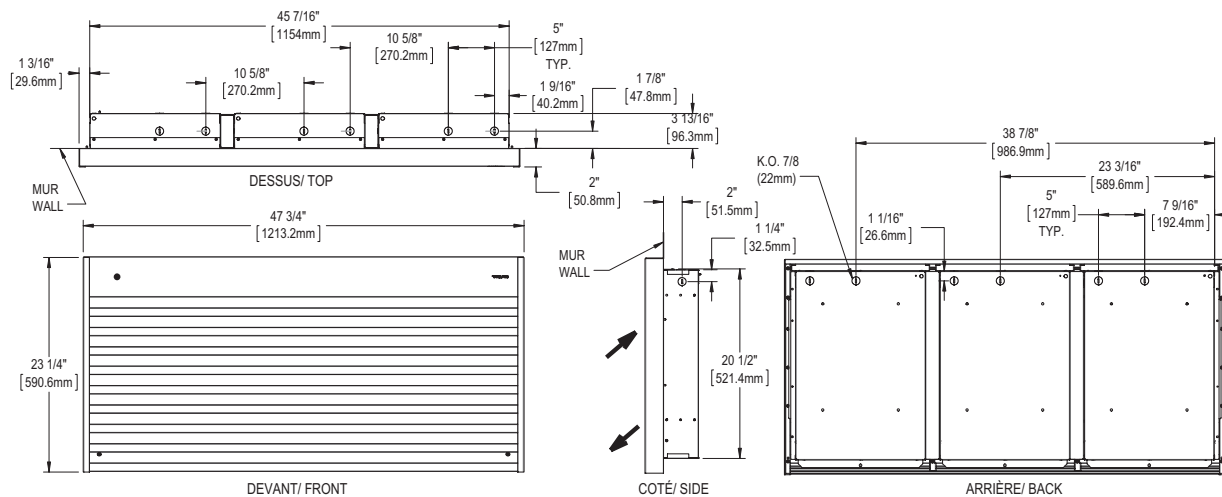



N.B. Cut off power supply at circuit breaker/fuse before proceeding to the installation and wiring connections. This product must be connected by a certified electrician, according to the electrical and building codes effective in your region.

When the unit is recessed, the flanged shoulders must rest on the finished surface of the wall.

WARNINGS

1. Recessed and surface installations must meet the minimum distances for single and double units (see figures 1 and 2). Note: 4800 W single units should be installed with a minimum distance of 8 inches (203 mm) from the floor.
2. Triple units must meet a minimum distance of 12 inches (305 mm) from the wall and 8 inch (203 mm) from the floor. For the opening of recessed installation of triple units, see figure 3.
3. Recessed structure requirement on outside walls must be the same as a window structure (refer to applicable building codes effective in your area).
4. For surface installation, put a wooden plate at the back of gypsum in order to fix the product to the wall securely. For the wooden plate dimensions, refer to the opening for the recessed application (see figures 2 and 3).

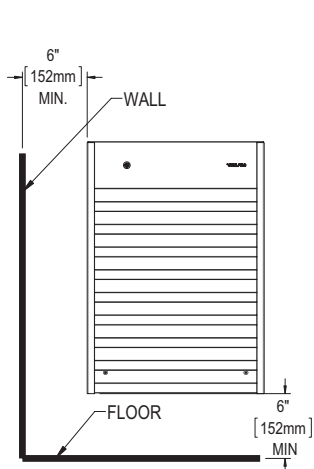

FIG. 1

FRONT
SURFACE INSTALLATION
SINGLE AND DOUBLE UNIT
REQUIRE (SURFACE ADAPTOR)

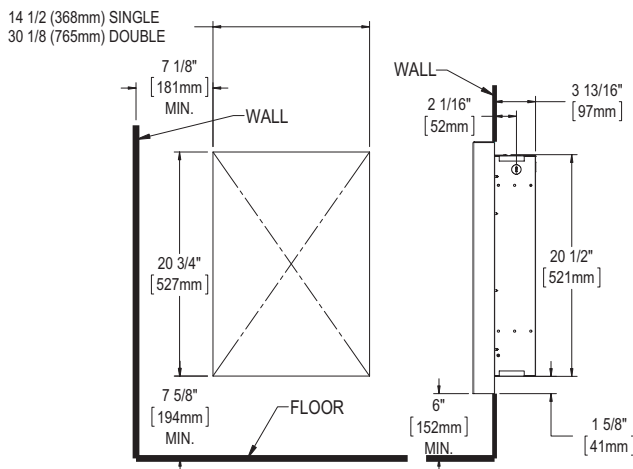

FIG. 2

OPENING
RECESSED INSTALLATION
SINGLE AND DOUBLE UNIT

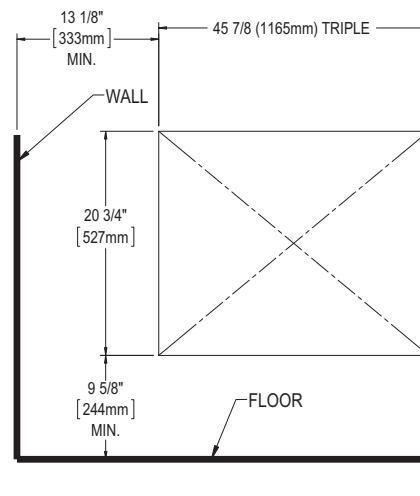

FIG. 3

OPENING
RECESSED INSTALLATION
TRIPLE UNIT

SURFACE INSTALLATION

1. Make sure you use the proper sleeve surface adaptor depending on the device you are installing: WFASA1 (single units), WFASA2 (double units), WFASA3 (triple units).
2. Unscrewed the two (2) screws holding the grid (see figure 4). Raise the bottom and gently pull up to release the grille (see figure 5).
3. Using the screws included with the sleeve adaptor, attach the sleeve adaptor to the frame (see figure 6).
4. Remove the inlet of the frame (see figure 6) by unscrewing the four (4) screws.
5. Open the KO to be used and insert the wire with connector into it.
6. Place the frame against the wall, level it and tighten it with four (4) wood screws (not included) into the holes provided for this purpose (see figure 7).
7. Replace the inlet, make the required electrical connections and replace the grille.

RECESSED INSTALLATION

1. The opening in the wall must first be made in accordance with acceptable standards (see figures 2 and 3, and Warning).
2. Unscrew the two (2) screws holding the grid (see figure 4). Raise the bottom and pull up to release the grille (see figure 5).
3. Remove the inlet of the frame (see figure 6) by unscrewing the four (4) screws.
4. Open the KO to be used and insert the wire with connector into it.
5. Insert the frame into the opening, press the flap against the wall. Screw in wood screws (not included) in the left and the right studs, through holes provided for this purpose (see figure 8).
6. Replace the inlet, make the required electrical connections and replace the grille.

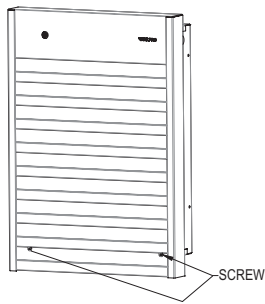

FIG. 4

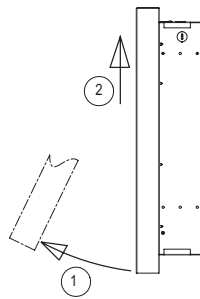

FIG. 5

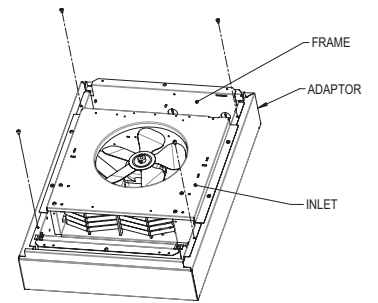

FIG. 6

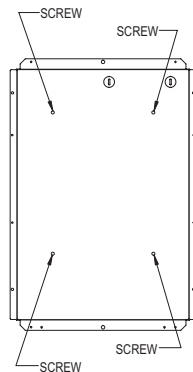

FIG. 7

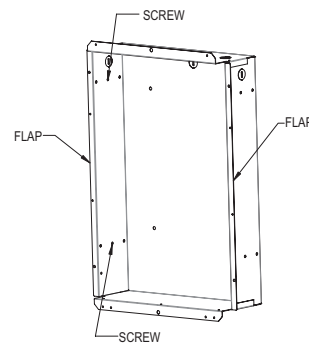

FIG. 8

INSTALLATION OF THERMOSTAT KNOBS

When purchasing a product with a thermostat (e.g. WFA4802T), two options are available:

OPTION A) TAMPER PROOF

Function: Prevents children from changing the room temperature.

Before installing the grille, insert the tamper proof button onto the shaft of the thermostat. Check the alignment between the tamper proof knob and the hole on the grille. Adjust, if necessary, using the thermostat support grooves.

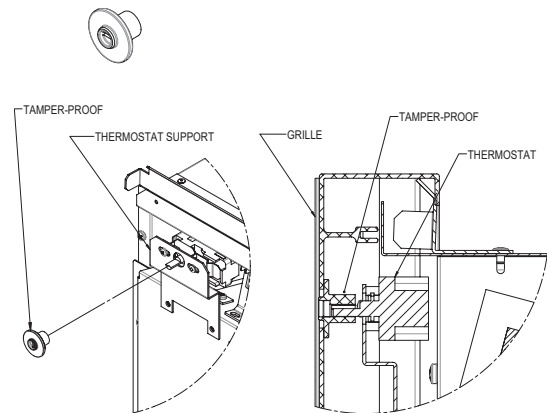

OPTION B) THERMOSTAT KNOB

After installation of the grille, insert the knob onto the shaft of the thermostat.

Note: If you ordered the grille without the thermostat hole by mistake, consult the diagram shown here for the dimensions to manually drill the hole.

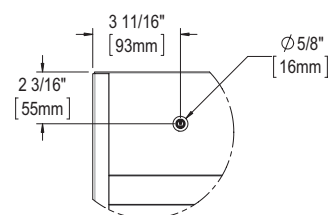

MAINTENANCE

N.B. In order for the warranty to be valid, the unit must be cleaned regularly.

Switch off the main breaker in the electrical panel before cleaning the unit. Use a soft rag for dusting. When cleaning, use only a damp rag and non-abrasive dish soap. If you use a cleaning product, always wipe the product off properly to avoid the discoloration of the unit. Do not use abrasive or chemical cleaners because they may damage the finishing. If the unit is used in a very dusty location, use a vacuum brush to remove dust and other foreign objects from the grilles. If needed, vacuum out the dust inside the unit. Note that cigarette smoke could yellow the discharge grille and that the best way to prevent it is to clean the unit on a regular basis.

Do not use cleaning products identified with these symbols:



TROUBLESHOOTING

PROBLEM	DEFECTIVE PART OR PART TO CHECK
The unit does not work	<ul style="list-style-type: none"> • The circuit breaker is in the OFF position or removed fuse • Defective thermostat or wrong thermostat setting • Activated thermal protection • Faulty connections
The unit runs continuously	<ul style="list-style-type: none"> • Defective thermostat or wrong thermostat setting • Heat losses higher than the unit capacity
The enclosure is extremely hot	<ul style="list-style-type: none"> • Defective thermal protection • Blocked air vents
The desired ambient temperature can never be reached	<ul style="list-style-type: none"> • One or more elements are defective • Defective thermostat or wrong thermostat setting • Voltage lower than that written on the nameplate • Heat losses higher than the unit capacity
Overheating	<ul style="list-style-type: none"> • Defective thermostat or wrong thermostat setting
The unit cycles under control of the thermal protection (overheat indicator)	<ul style="list-style-type: none"> • Blocked air vents • Defective motor
The breaker trips when the heater is turned on	<ul style="list-style-type: none"> • Faulty connections • Voltage higher than that written on the nameplate

N.B. If you do not solve the problem after checking these points, cut off the power supply at the main electrical panel and contact our customer service (see the "Limited warranty" section to obtain the phone numbers).

REPLACEMENT COMPONENT LIST

REF. #	PART #	DESCRIPTION
1	BLA-003	FAN BLADE 8"
2	BOUT-033W	THERMOSTAT BUTTON, WHITE
2	BOUT-033A	THERMOSTAT BUTTON, WHITE
2	BOUT-033BK	THERMOSTAT BUTTON, BLACK
3	BOUT-026W	TAMPER-PROOF, WHIITE
3	BOUT-026A	TAMPER-PROOF, ALMOND
3	BOUT-026BK	TAMPER-PROOF, BLACK
4	---	---
5	ELF-WFA1502	ELEMENT ASSEMBLY WFA1502
5	ELF-WFA1503	ELEMENT ASSEMBLY WFA1503
5	ELF-WFA1506	ELEMENT ASSEMBLY WFA1506
5	ELF-WFA1507	ELEMENT ASSEMBLY WFA1507
5	ELF-WFA2002	ELEMENT ASSEMBLY WFA2002
5	ELF-WFA2003	ELEMENT ASSEMBLY WFA2003
5	ELF-WFA2006	ELEMENT ASSEMBLY WFA2006
5	ELF-WFA2007	ELEMENT ASSEMBLY WFA2007
5	ELF-WFA2008	ELEMENT ASSEMBLY WFA2008
5	ELF-WFA3002	ELEMENT ASSEMBLY WFA3002
5	ELF-WFA3003	ELEMENT ASSEMBLY WFA3003
5	ELF-WFA3006	ELEMENT ASSEMBLY WFA3006
5	ELF-WFA3007	ELEMENT ASSEMBLY WFA3007
5	ELF-WFA4002	ELEMENT ASSEMBLY WFA4002
5	ELF-WFA4003	ELEMENT ASSEMBLY WFA4003
5	ELF-WFA4006	ELEMENT ASSEMBLY WFA4006
5	ELF-WFA4007	ELEMENT ASSEMBLY WFA4007
5	ELF-WFA4008	ELEMENT ASSEMBLY WFA4008
5	ELF-WFA4802	ELEMENT ASSEMBLY WFA4802
5	ELF-WFA4803	ELEMENT ASSEMBLY WFA4803
5	ELF-WFA4805	ELEMENT ASSEMBLY WFA4805
5	ELF-WFA4806	ELEMENT ASSEMBLY WFA4806
5	ELF-WFA4807	ELEMENT ASSEMBLY WFA4807
5	ELF-WFA4808	ELEMENT ASSEMBLY WFA4808
6	PROT-006	THERMAL PROTECTION 1500-2000W
6	PROT-005	THERMAL PROTECTION 3000-12000W
7	ST-017	THERMOSTAT SP 120 TO 277V-22A, 600V-10A
7	ST-007	THERMOSTAT SP 120 TO 277V-25A, 600V-10A
7	ST-013	THERMOSTAT DP 120 TO 277V-25A, 600V-10A

REF. #	PART #	DESCRIPTION
CONTROL TRANSFORMER		
8	TRF200040D	TRANSFORMER 208-240/24/40VA CL.2
8	TRF700025	TRANSFORMER 277/24/25VA
8	TRF720025	TRANSFORMER 277/240/25VA
8	TRF300040	TRANSFORMER 347/24/40VA CLS 2
8	TRF320025	TRANSFORMER 347/240/25VA
8	TRF500025D	TRANSFORMER 240-480/12-24/25VA
8	TRF520025	TRANSFORMER 480/240/25VA
8	TRF600040	TRANSFORMER 600/24/40VA CLS 2
8	TRF620025	TRANSFORMER 600/240/25VA
CONTACTOR		
9	CONT-3002	CONTACTOR 2P/24V/30A RESISTIVE
9	CONT-3503	CONTACTOR 3P/24V/35A RESISTIVE
9	CONT-5002	CONTACTOR 2P/24V/50A RESISTIVE
9	CONT-3022	CONTACTOR 2P/240-208V/30A RESISTIVE
9	CONT-4023	CONTACTOR 3P/240-208V/40A RESISTIVE
9	CONT-5023	CONTACTOR 3P/240-208V/50A RESISTIVE
MOTOR TRANSFORMER		
10	TRF720100	TRANSFORMER 277/240/100VA
10	TRF520100	TRANSFORMER 480/240/100VA
10	TRF620100	TRANSFORMER 600/240/100VA
11	MO-016	MOTOR 208/240V 50/60HZ 0.4A
12	M-WFA100Z*	GRILL ASSY WFA-1
12	M-WFA100TZ*	GRILL ASSY WFA-1, THERMOSTAT
12	M-WFA200Z*	GRILL ASSY WFA-2
12	M-WFA200TZ*	GRILL ASSY WFA-2, THERMOSTAT
12	M-WFA300Z*	GRILL ASSY WFA-3
12	M-WFA300TZ*	GRILL ASSY WFA-3, THERMOSTAT
13	SWI-027	MOTOR SWITCH 600V/30A, 2 POLES
13	SWI-028	DISCON. SWITCH 600V/40A 2POLES/3POLES
13	SWI-029	DISCON. SWITCH 600V/60A 2POLES/3POLES

* Add **W** for white, **SW** for silica white, **A** for almond, **S** for silver, **BK** for black, **CHAR** for textured charcoal, **NIC** for nickel, **CHA** for champagne, **LB** for light bronze, **BR** for dark brown or **CAP** for clear anodized (paint)

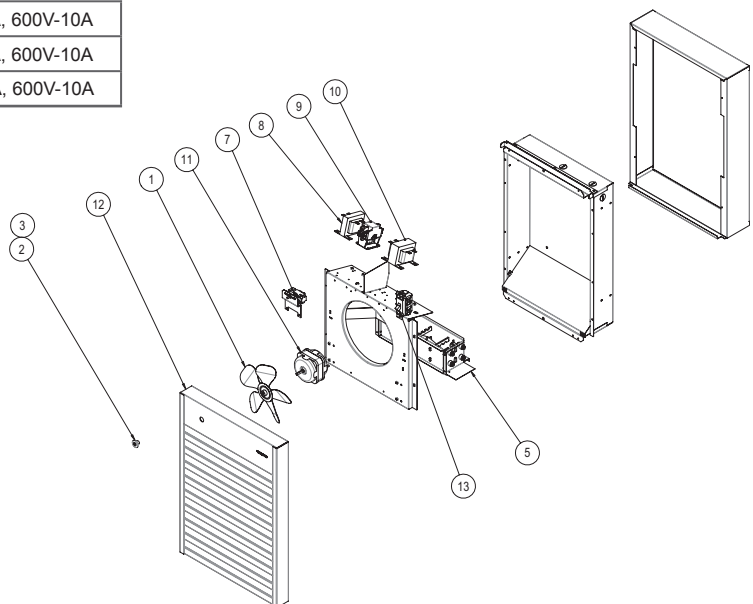

LIMITED WARRANTY

This limited warranty is offered by Stelpro Design inc. ("Stelpro") and applies to the following products made by Stelpro: WFA model. **Please read this limited warranty carefully. Subject to the terms of this warranty**, Stelpro warrants its products and their components against defects in workmanship and/or materials for the following periods from the date of purchase: **3 years**. This warranty applies only to the original purchaser; it is non-transferable and cannot be extended.

CLAIM PROCEDURE

If at any time during the warranty period the unit becomes defective, you must cut off the power supply at the main electrical panel and contact 1) your installer or distributor, 2) your service center or 3) Stelpro's customer service department. In all cases, you must have a **copy of the invoice** and provide the **information written on the product nameplate**. Stelpro reserves the right to examine or to ask one of its representatives to examine the product itself or any part of it before honoring the warranty. Stelpro reserves the right to **replace** the entire unit, **refund** its purchase price or **repair** a defective part. Please note that repairs made within the warranty period must be authorized in advance in writing by Stelpro and carried out by persons authorized by Stelpro.

Before returning a product to Stelpro, you must have a Stelpro authorization number (RMA). To obtain it, call the customer service department at: **1-800-363-3414** (electricians and distributors - French), **1-800-343-1022** (electricians and distributors - English), or **1-866-766-6020** (consumers). The authorization number must be clearly written on the parcel or it will be refused.

CONDITIONS, EXCLUSIONS AND DISCLAIMER OF LIABILITY

This warranty is exclusive and in lieu of all other representations and warranties (except of title), expressed or implied, and Stelpro expressly disclaims and excludes any implied warranty of merchantability or implied warranty of fitness for a particular purpose.

Stelpro's liability with respect to products is limited as provided above. Stelpro shall not be subject to any other obligations or liabilities whatsoever, whether based on contract, tort or other theories of law, with respect to goods or services furnished by it, or any undertakings, acts or omissions relating thereto. Without limiting the generality of the foregoing, Stelpro expressly disclaims any liability for property or personal injury damages, penalties, special or punitive damages, damages for lost profits, loss of use of equipment, cost of capital, cost of substitute products, facilities or services, shutdowns, slowdowns, or for other types of economic loss or for claims of a dealer's customers or any third party for such damages. Stelpro specifically disclaims all consequential, incidental and contingent damages whatsoever.

This warranty does not cover any damages or failures resulting from: 1) a faulty installation or improper storage; 2) an abusive or abnormal use, lack of maintenance, improper maintenance (other than that prescribed by Stelpro) or a use other than that for which the unit was designed; 3) a natural disaster or an event out of Stelpro's control, including, but not limited to, hurricanes, tornadoes, earthquakes, terrorist attacks, wars, overvoltage, flooding, water damages, etc. This warranty does not cover any accidental or intentional losses or damages nor does it cover damages caused by negligence of the user or owner of the product. Moreover, it does not cover the cost of disconnection, transport, and installation.

The warranty is limited to the repair or the replacement of the unit or the refund of its purchase price, **at the discretion of Stelpro**. Any parts replaced or repaired within the warranty period with the written authorization of Stelpro will be warranted for the remainder of the original warranty period. This warranty will be considered null and void and Stelpro will have the right to refuse any claims if **products have been altered** without the written authorization of Stelpro and if the nameplate numbers have been removed or modified. This warranty does not cover scratches, dents, corrosion or discoloration caused by excessive heat, chemical cleaning products and abrasive agents. It does not cover any damage that occurred during the shipping.

Some states and provinces do not allow the exclusion or limitation of incidental or consequential damages and some of them do not allow limitations on how long an implied warranty lasts, so these exclusions or limitations may not apply to you. This warranty gives you specific legal rights and you may have other rights which vary from state to state or from province to province.