

Antenna - RAD-ISM-900-ANT-YAGI-3-N - 2867801

Please be informed that the data shown in this PDF Document is generated from our Online Catalog. Please find the complete data in the user's documentation. Our General Terms of Use for Downloads are valid (<http://phoenixcontact.com/download>)

Directional antenna, 868 MHz / 900 MHz, gain: 5 dBi, polarization: linear, opening angle: h/v 168°/78°, degree of protection: IP65, connection: N (female), incl. mounting bracket and mast clips



Your advantages

- ✓ For large distances
- ✓ For stationary or linear mobile applications
- ✓ For point-to-point connections

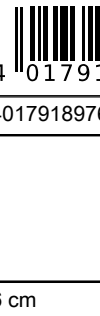

Key Commercial Data

Packing unit	1 pc
GTIN	 4 017918 976668
GTIN	4017918976668

Technical data

Dimensions

Width	6 cm
Height	17 cm
Fixed cable length	0.60 m

Ambient conditions

Degree of protection	IP65
Ambient temperature (operation)	-40 °C ... 80 °C

General

With connecting cable	yes
Frequency range	900 MHz
	900 MHz
Horizontal beamwidth	168 °
Vertical beamwidth	78 °

Antenna - RAD-ISM-900-ANT-YAGI-3-N - 2867801

Technical data

General

Polarization	Linear vertical or horizontal
Impedance	50 Ω
Gain	5 dBi
Wind velocity	200 km/h
Connection method	N (female) with cable (0.6 m)
Fixed cable length	0.60 m
Material	Aluminum (Antenna housing)
	V2A (Bracket)
	V2A (U-shaped screw)
Mounting type	Mast mounting
External diameter	32 mm ... 60 mm (Mast)

Environmental Product Compliance

China RoHS	Environmentally friendly use period: unlimited = EFUP-e
	No hazardous substances above threshold values

Drawings

Schematic diagram

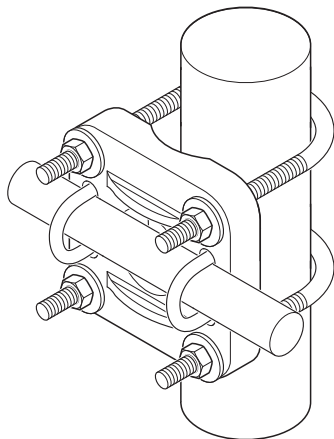

Schematic diagram

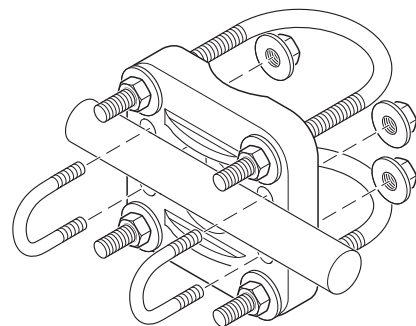

Mast mounting

Antenna - RAD-ISM-900-ANT-YAGI-3-N - 2867801

Schematic diagram

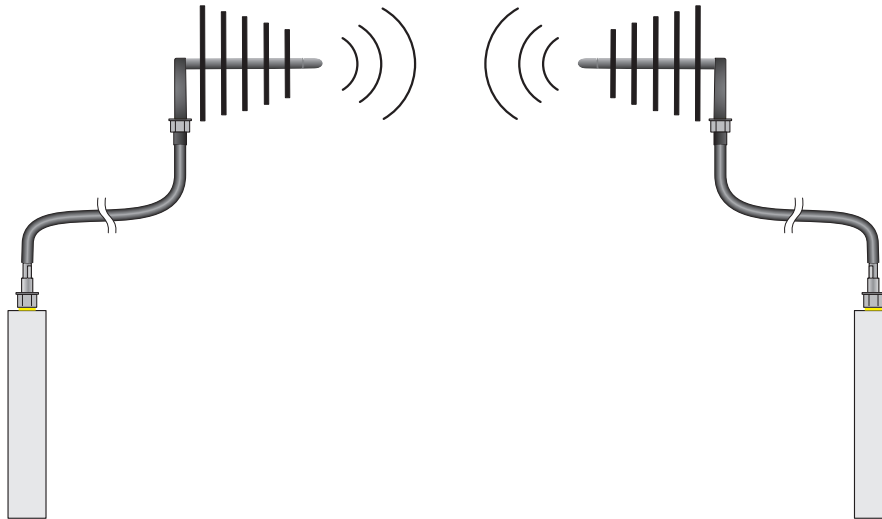

Phoenix Contact 2019 © - all rights reserved
<http://www.phoenixcontact.com>

PHOENIX CONTACT GmbH & Co. KG
Flachmarktstr. 8
32825 Blomberg
Germany
Tel. +49 5235 300
Fax +49 5235 3 41200
<http://www.phoenixcontact.com>