

PRODUCT INFORMATION PACKET



Model No: 191570.00

Catalog No: 191570.00

General Purpose Motor, 2 & 1.50 HP, 3 Ph, 60 & 50 Hz, 208-230/460 & 190/380 V, 1800 & 1500 RPM,
145TC Frame, TEFC



Regal and Leeson are trademarks of Regal Rexnord Corporation or one of its affiliated companies.

©2023 Regal Rexnord Corporation, All Rights Reserved. MC017097E





Nameplate Specifications

Phase	3	Output HP	2 & 1.50 Hp
Output KW	1.5 & 1.1 kW	Voltage	208-230/460 & 190/380 V
Speed	1750 & 1450 rpm	Service Factor	1.15 & 1.15
Frame	145TC	Enclosure	Totally Enclosed Fan Cooled
Thermal Protection	No Protection	Efficiency	86.5 & 86.5 %
Ambient Temperature	40 °C	Frequency	60 & 50 Hz
Current	5.8-5.4/2.7 & 5/2.5 A	Power Factor	80
Duty	Continuous	Insulation Class	F
Design Code	B	KVA Code	L
Drive End Bearing Size	6205	Opp Drive End Bearing Size	6205
UL	Recognized	CSA	Y
CE	Y	IP Code	55
Number of Speeds	1		

Technical Specifications

Electrical Type	Squirrel Cage Inverter Rated	Starting Method	Line Or Inverter
Poles	4	Rotation	Reversible
Resistance Main	0 Ohms	Mounting	Round
Motor Orientation	Horizontal	Drive End Bearing	Ball
Opp Drive End Bearing	Ball	Frame Material	Stainless Steel
Shaft Type	T	Overall Length	13.62 in
Shaft Diameter	0.875 in	Shaft Extension	2.12 in
Assembly/Box Mounting	F1/F2 CAPABLE	Inverter Load	CONSTANT 20:1
Connection Drawing	005010.01	Outline Drawing	16992700

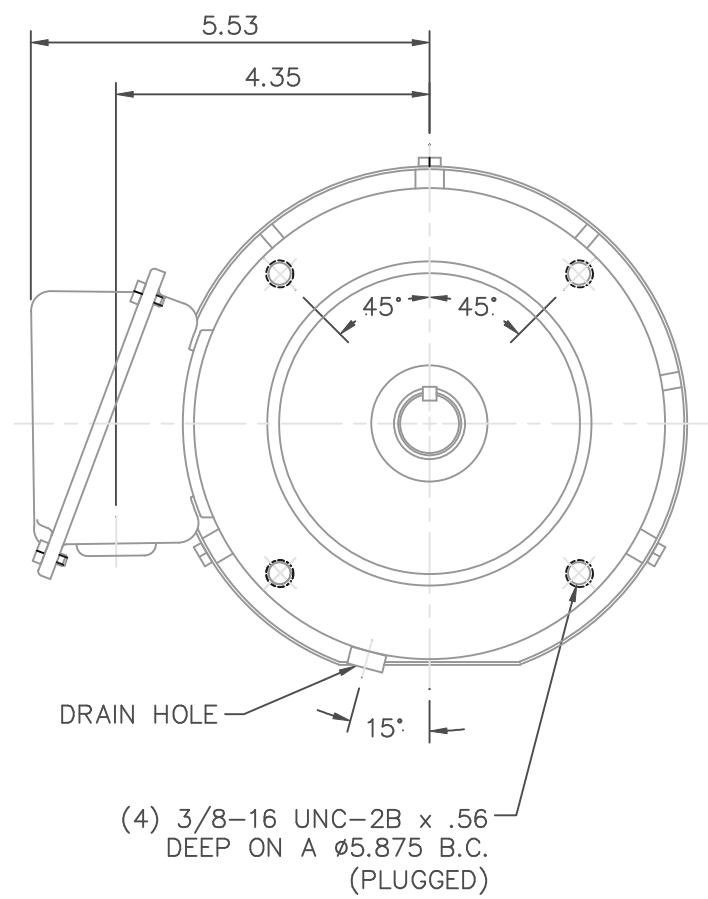
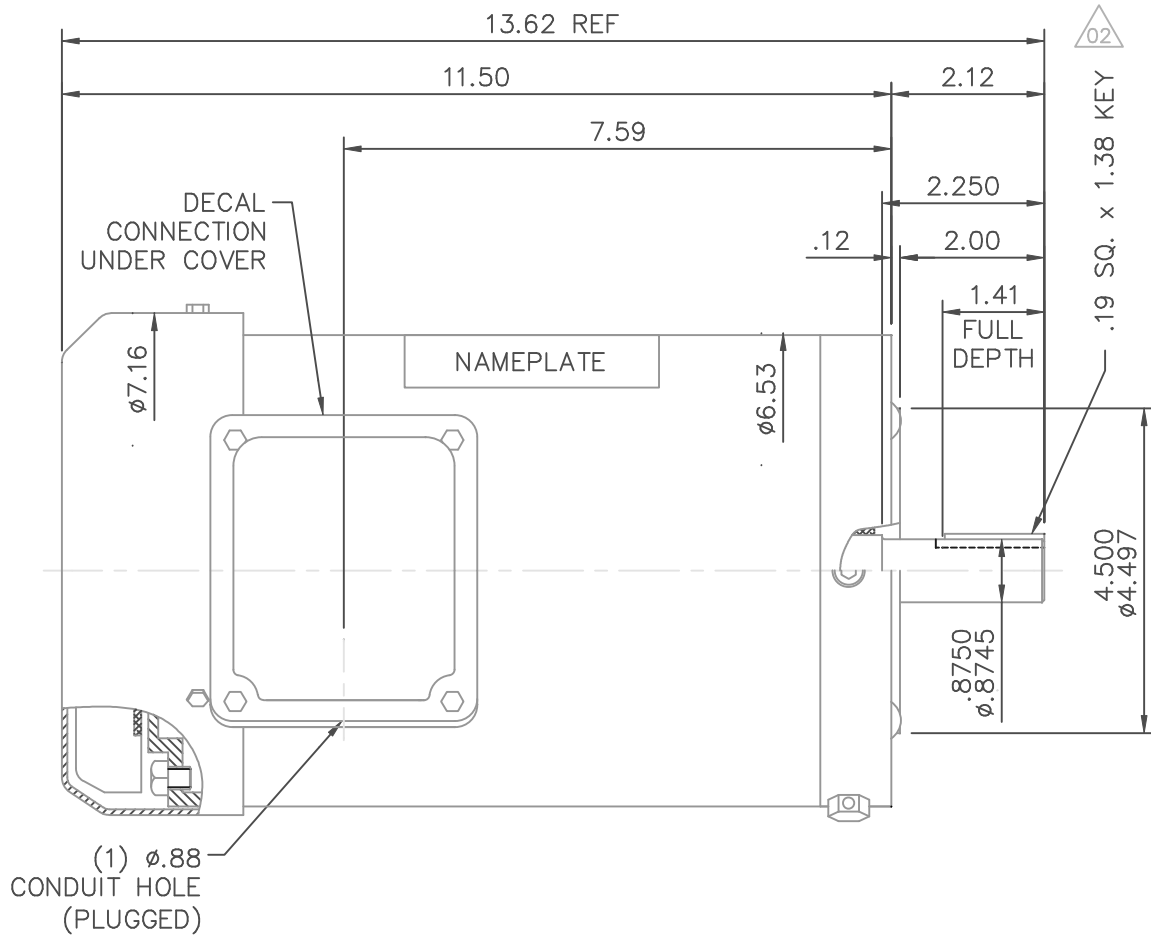

MAXIMUM FACE RUNOUT TO BE .004 T.I.R.
 MAXIMUM PILOT ECCENTRICITY .004 T.I.R.
 PERMISSIBLE SHAFT RUNOUT .002 T.I.R.

GASKETS THROUGHOUT

				TOLERANCES UNLESS SPECIFIED		 ELECTRIC MOTORS GEARMOTORS AND DRIVES	DRAWN	MGM 04/09/03		
				DEC.	INCHES		CHK	RDW 04/09/03		
				.X	±.1		APPD			
				.XX	±.03	TITLE	OUTLINE - 143-145TC FRAME	SCALE	3=8	
02	UPDATED SHAFT EXT DIMS	RDW 4/26/04	SW	.XXX	±.005		TEFC - "C" FACE	REF		
01	CONDUIT HOLE WAS 1/2-14 NPT, DIM .157 WAS .12	SW 10/7/2003	RDW	.XXXX	±.0005	MAT'L.		FMF		
NO.	REVISION	BY & DATE	CHK	ANG	±1/2'	FINISH		PREV		
THIS DRAWING IN DESIGN AND DETAIL IS OUR PROPERTY AND MUST NOT BE USED EXCEPT IN CONNECTION WITH OUR WORK ALL RIGHTS OF DESIGN AND INVENTION ARE RESERVED THIS IS AN ELECTRONICALLY GENERATED DOCUMENT - DO NOT SCALE THIS PRINT				RFP		CAD FILE	16992700	SIZE	DRAWING NO.	REV.
				DIST				A	169927.00	01

005010-01

VIEW FROM OUTSIDE OF MOTOR AT SWITCH END.

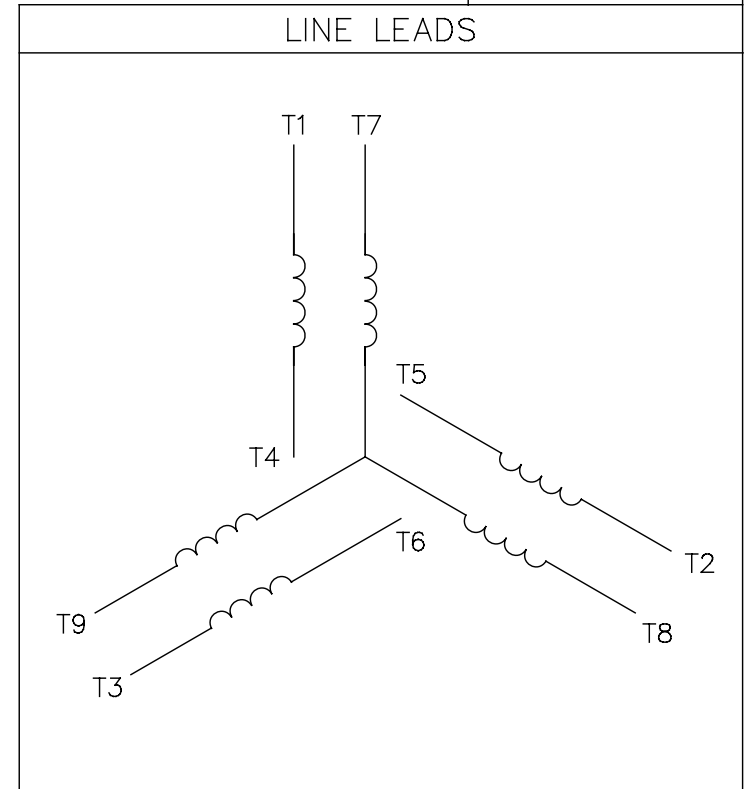

VOLTAGE	L1	L2	L3	JOIN & INSULATE
HIGH	T1	T2	T3	(T4,T7) (T5,T8) (T6,T9)
LOW	T1,T7	T2,T8	T3,T9	T4,T5,T6

				TOLERANCES UNLESS SPECIFIED		REGAL ™ Regal Beloit America, Inc.		DRAWN RDW 04/12/02			
				DEC.	INCHES			CHK			
				.X	±.1			APPD			
				.XX	±.01	TITLE EXTERNAL WIRING DIAGRAM 3 PHASE W/O PROTECTOR		SCALE 1=1			
				.XXX	±.005			REF FIG.2-51			
A	UPDATED TO REGAL LOGO	SAJ 06/26/15	AJY	.XXXX	±.0005	MAT'L DECAL - 004014		FMF			
NO.	REVISION	BY & DATE	CHK	ANG	±1/2"	FINISH		PREV			
THIS DRAWING IN DESIGN AND DETAIL IS OUR PROPERTY AND MUST NOT BE USED EXCEPT IN CONNECTION WITH OUR WORK ALL RIGHTS OF DESIGN AND INVENTION ARE RESERVED THIS IS AN ELECTRONICALLY GENERATED DOCUMENT - DO NOT SCALE THIS PRINT				RFP	04/12/02	CAD FILE		00501001	SIZE	DRAWING NO.	REV.
				DIST		BRF-NLV		A	005010-01	A	



1051 CHEYENNE AVE.
GRAFTON, WI 53024
PH. 262-277-8810

DATA VOLTS: 460

CERTIFICATION DATA SHEET

CONN. DIAGRAM: 005010.01
OUTLINE: 16992700
WINDING: QT63422

CAT #: 191570.00

FR 3

TYPICAL MOTOR PERFORMANCE DATA

HP	KW	SYNC RPM	FL RPM	FRAME	ENCLOSURE	TYPE	KVA CODE	DESIGN
2	1.5	1800	1754	145TC	TEFC	NA	L	B

PH	HZ	VOLTS	AMPS	START TYPE	DUTY	INSL	S.F.	AMB	ELEV.
3	60/50	208-230/460#190/380	5.8-5.4/2.7&5/2.5	LINE OR INVERTER	CONT	F	1.15	40	3300

F.L. EFF	88.4	3/4 LD EFF	88.2	1/2 LD EFF	85.9	GTD EFF	ELECT. TYPE
F.L. PF	78.3	3/4 LD PF	72.5	1/2 LD PF	60.5	0.0	SQ CAGE INV RATED

F.L. TORQUE	LR AMPS @ 460 V	L.R. TORQUE	B.D. TORQUE	F.L. RISE (° C)
6.0 LB-FT	23.4	17.4 LB-FT 290%	25.4 LB-FT 423%	46

PRESSURE @ 3	SOUND	POWER	ROTOR WK²	MAX. LOAD WK²	SAFE STALL TIME	STARTS/HOUR	MOTOR WGT
999 dBA	1008 dBA		0.00 LB-FT²	0 LB-FT²	10 SEC.	0	0 LB.

***** SUPPLEMENTAL INFORMATION *****

DE BRACKET TYPE	ODE BRACKET TYPE	MOUNT TYPE	MOTOR ORIENTATION	SEVERE DUTY	HAZARDOUS LOCATION	DRIP COVER	SCREENS	PAINT
C-FACE	STANDARD	ROUND	HORIZONTAL	NO	NONE	NO	NONE	WATTSAVER

BEARINGS		GREASE	SHAFT TYPE	SPECIAL DE	SPECIAL ODE	SHAFT MATERIAL	FRAME MATERIAL
DE	ODE	POLYREX EM	T	NONE	NONE	303 STAINLESS (C-501)	STAINLESS STEEL
BALL	BALL						
6205	6205						

THERMOSTATS	PROTECTORS	WDG RTD's	BRG RTD's	THERMISTORS	CONTROL	SPACE HEATERS
NONE	NOT	NONE	NONE	NONE	FALSE	NA

R1 (ohms/ph)	R2 (ohms/ph)	X1 (ohms/ph)	X2 (ohms/ph)	Xm (ohms/ph)	VIBRATION (in/sec)	FLOAT
0	0	0	0	0	0.150	ODE

* N O T E S *	INVERTER TORQUE: CONSTANT 20:1 INV. HP SPEED RANGE: 2.0 X BASE SPEED					
	ENCODER: NONE NONE NONE					
	BRAKE: NONE NONE NONE					
	FT-LB: NA VOLTAGE: NONE					
	H.Z: NONE PPR					

DATE:	9/6/2018	UL: Y
-------	----------	-------

Data Sheet

Date: 9/6/2018

191570.00



Data @ **460 V**

Motor Load Data

Load	0%	25%	50%	75%	100%	115%	125%	LR
Current (Amps)	1.40	1.60	1.80	2.20	2.70	2.96	3.2	23.4
Torque (ft-lb)	0.00	1.47	2.95	4.5	6.0	6.9	7.5	17.4
RPM	1800	1789	1779	1767	1754	1,747	1741	0
Efficiency (%)		77.9	85.9	88.2	88.4	89.0	88.1	
P.F. (%)	8.9	37.6	60.5	72.5	78.3	81.7	83.0	51.5

Motor Speed Data

	LR	Pull-Up	BD	Rated	Idle
Speed (RPM)	0	321	1364	1754	1800
Current (Amps)	23.4	22.9	14.2	2.70	1.40
Torque (ft-lb)	17.4	14.0	25.4	6.0	0.00

Information Block				
HP	2.0			
Sync. RPM	1800			
Frame	0			
Enclosure	TEFC			
Construction	NA			
Voltage	208-230/460#190/380 V			
Frequency	60 Hz			
Design	B			
LR Code letter	L			
Service Factor	1.15			
Temp Rise @ FL	46 ° C			
Duty	CONT			
Ambient	40 ° C			
Elevation	1,000 feet			
Rotor/Shaft wk ²	0.00 Lb-Ft ²			
Ref Wdg	QT63422 FR			
Sound Pressure @ 1M	999 dBA			
VFD Rating	CONSTANT 20:1			
Outline Dwg	16992700			
Conn. Diag	005010.01			
Additional Specifications:				
0				
0				
EQUIV CKT (OHMS / PHASE)				
R1	R2	X1	X2	Xm
0.0000	0.0000	0.0000	0.0000	0.0000

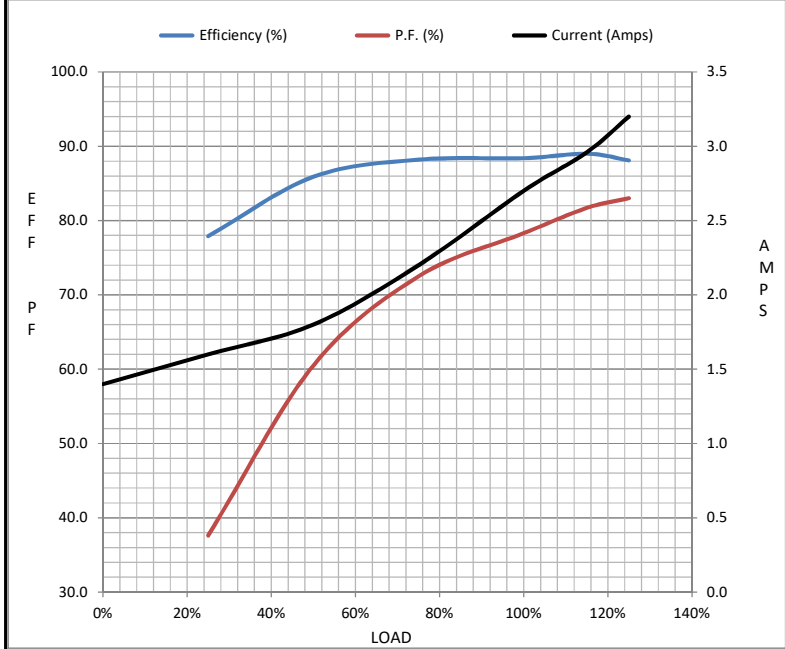

Speed - Torque Curve

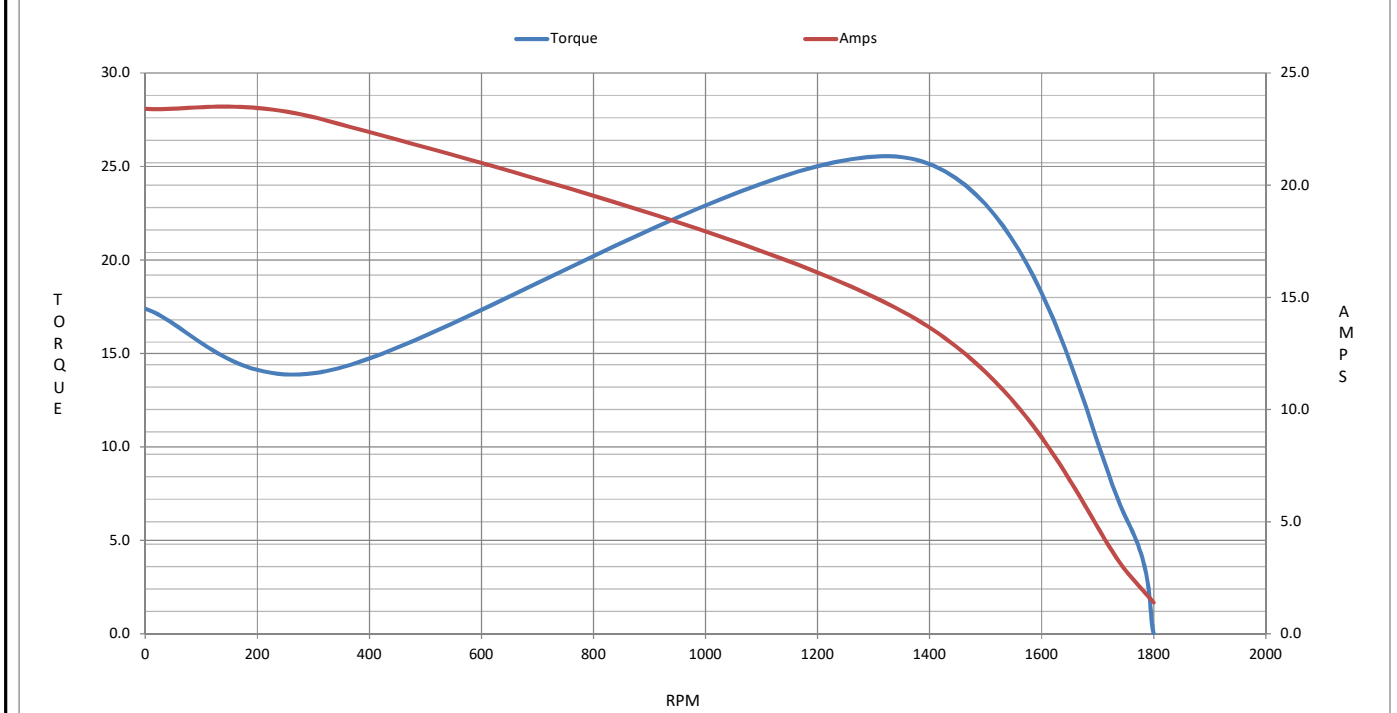

EC Declaration of Conformity

The undersigned representing
the manufacturer:

Regal Beloit America
100 East Randolph St.
Wausau, WI 54401

and the authorized representative
established within the Community:

Marathon Electric UK
6F Thistleton Road Ind. Estate
Market Overton
Oakham, Rutland LE15 7PP UK

are committed to providing customers with products that comply with applicable regulations and international protocols to which they are subject, including the requirements of the European Parliament Directive on the Harmonization of the laws relating to electrical equipment designed for use within certain voltage limits (2014/35/EU).

Regal Beloit America declares that the following product(s), to which this declaration relates, are in conformity with the relevant sections of the EC standards listed below.

This statement supersedes any statements previously issued pertaining to the product(s) listed below and is subject to change without notice.

Model No : 191570.00

(Model No. may contain prefix and/or suffix characters)

Catalog No : 191570.00

Rework No : N/A

Directives :

Low Voltage Directive 2014/35/EU

Harmonized Standards Used :

EN 60034-1: 2010 (IEC 60034-1: 2010)

EN 60034-5: 2001/A1:2007 (IEC 60034-5: 2000/A1:2006)

Authorized Representative:

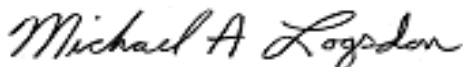

Michael A. Logsdon
Vice President, Technology

Authorized Representative in the Community:



Julian Clark
Marketing Engineer

Created on 09/01/2022

CE 22