

BALDOR® • ***RELIANCE***

Product Information Packet

CSWDM3546

1HP,1740RPM,3PH,60HZ,56C,3518M,TENV,F1,N

Part Detail							
Revision:	C	Status:	PRD/A	Change #:		Proprietary:	No
Type:	AC	Prod. Type:	3518M	Elec. Spec:	35WGP439	CD Diagram:	
Enclosure:	TENV	Mfg Plant:		Mech. Spec:	35S630	Layout:	
Frame:	56C	Mounting:	F1	Poles:	04	Created Date:	08-06-2010
Base:	RG	Rotation:	R	Insulation:	F	Eff. Date:	06-17-2011
Leads:	9#18	Literature:		Elec. Diagram:		Replaced By:	

Nameplate NP1496L

CAT.NO.	CSWDM3546						
SPEC.	35S630P439G1						
HP	1						
VOLTS	208-230/460						
AMP	3.2-3/1.5						
RPM	1740						
FRAME	56C	HZ	60	PH	3		
SER.F.	1.15	CODE	M	DES	B	CLASS	F
NEMA-NOM-EFF	82.5	PF	74				
RATING	40C AMB-CONT						
CC			USABLE AT 208V				
DE	6205	ODE	6203				
ENCL	TENV	SN					

Parts List		
Part Number	Description	Quantity
SA201510	SA 35S630P439G1	1.000 EA
RA188805	RA 35S630P439G1	1.000 EA
NS2512A01	INSULATOR, CONDUIT BOX X	1.000 EA
35CB5001A03	CONDUIT BOX KIT, FOR SUPER II WASHDOWN	1.000 EA
11XW1032G06	10-32 X .38, TAPTITE II, HEX WSHR SLTD U	1.000 EA
35EP3100M72MU	SPL FR EP-ENCL-203 BRG-DIE CAST ALUM(BAL	1.000 EA
HW4500A33	1/8 NPT STAINLESS,HOLO-KROME #13002,PRES	3.000 EA
HW5100A03SP	WAVY WASHER (W1543-017)	1.000 EA
35EP3300A75MU	PU E.P., CAST-FACE MTD-56C-205 BRG(BALL	1.000 EA
HW4500A33	1/8 NPT STAINLESS,HOLO-KROME #13002,PRES	3.000 EA
HW4606A02	JM CLIPPER/SEAL (LWE-0938-1624-AL23)	1.000 EA
12XN1032S20	10-32 X 1-1/4 HEX M.S. , STAINLESS STEEL	2.000 EA
HA1049A01	DUBO LOK WASHER SIZE 10 (NYLON LOCK SEAL	2.000 EA
HA1049A01	DUBO LOK WASHER SIZE 10 (NYLON LOCK SEAL	4.000 EA
HW2502D13	SS KEY, 3/16 SQ X 1.375	1.000 EA
HA7000A04	KEY RETAINER 0.625 DIA SHAFTS	1.000 EA
MJ5001A02	732 CL SEALANT 3 OZ DIXIE BEARING 289100	0.001 EA
85XU0407S04	4X1/4 U DRIVE PIN STAINLESS	2.000 EA
LB1164	LABEL,WARNING AND DRAIN	1.000 EA
MJ1000A75	GREASE, POLYREX EM EXXON	0.050 LB
HA3100S12	THRUBOLT 7.625 LENGTH 1.250 TH LENGTH SS	4.000 EA
LC0005	CONN.DIA.,TY M,9-LD,DUAL VOLT,REVERSING	1.000 EA
LB1125C01	STD (STOCK) CARTON LABEL BALDOR WITH FLA	1.000 EA
NP1496L	WD, SS, UL CSA CC, W/O THERMAL, LASER	1.000 EA

Parts List (continued)

Part Number	Description	Quantity
PA1000	PACKING GROUP 3500 SHORT	1.000 EA

Performance Data at 460V, 60Hz, 1.0HP (Typical performance - Not guaranteed values)
General Characteristics

Full Load Torque:	2.99 LB-FT	Start Configuration:	DOL
No-Load Current:	0.997 Amps	Break-Down Torque:	13.7 LB-FT
Line-line Res. @ 25°C.:	16.0 Ohms A Ph / 0.0 Ohms B Ph	Pull-Up Torque:	8.94 LB-FT
Temp. Rise @ Rated Load:	79 C	Locked-Rotor Torque:	10.3 LB-FT
Temp. Rise @ S.F. Load:	98 C	Starting Current:	13.2 Amps

Load Characteristics

% of Rated Load	25	50	75	100	125	150	S.F.
Power Factor:	33.0	51.0	65.0	74.0	80.0	84.0	78.0
Efficiency:	69.7	79.7	82.6	83.2	82.5	81.1	82.8
Speed:	1786.0	1771.0	1757.0	1742.0	1723.0	1704.0	1731.0
Line Amperes:	1.03	1.15	1.32	1.51	1.76	2.06	1.66

Performance Graph at 460V, 60Hz, 1.0HP Typical performance - Not guaranteed values

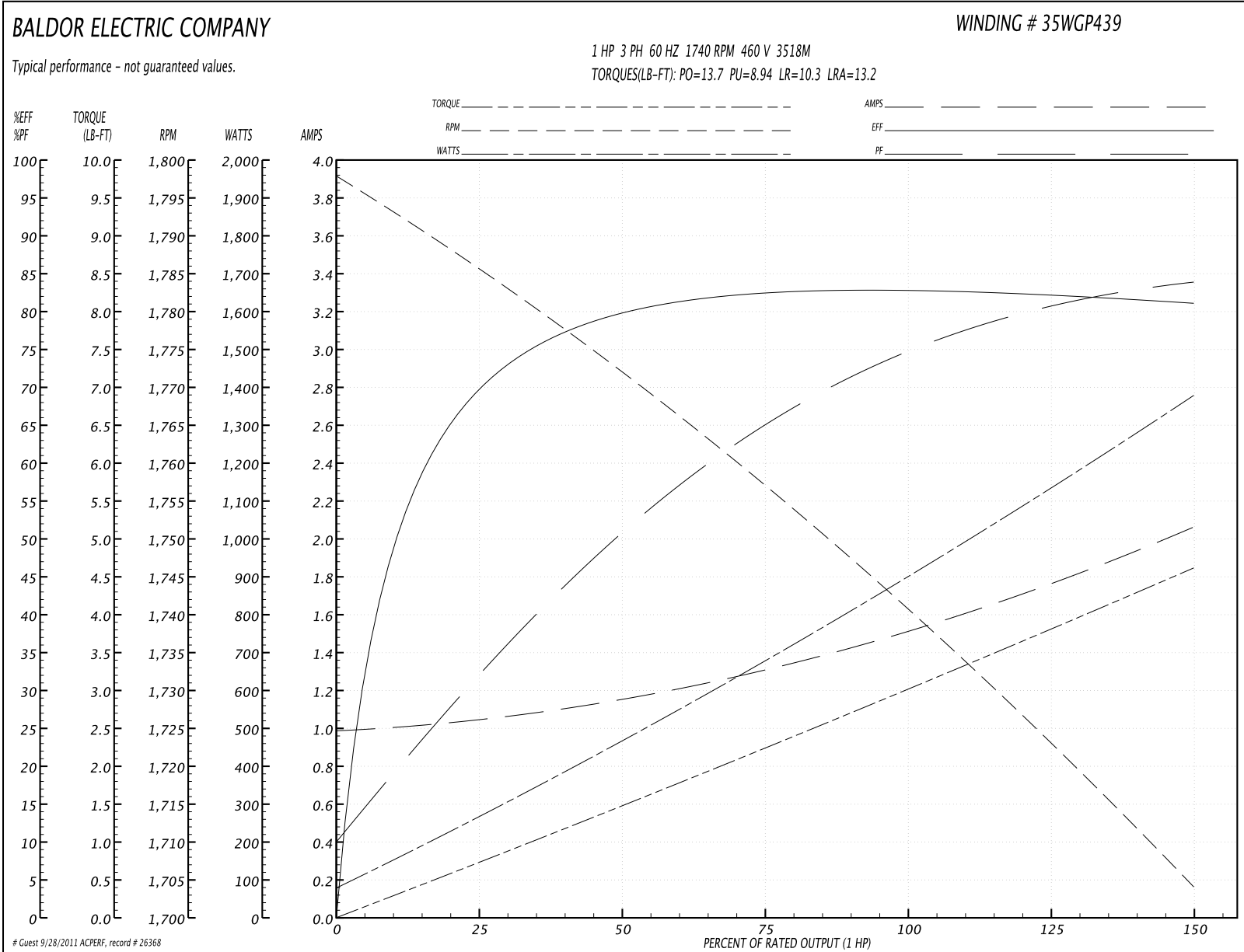

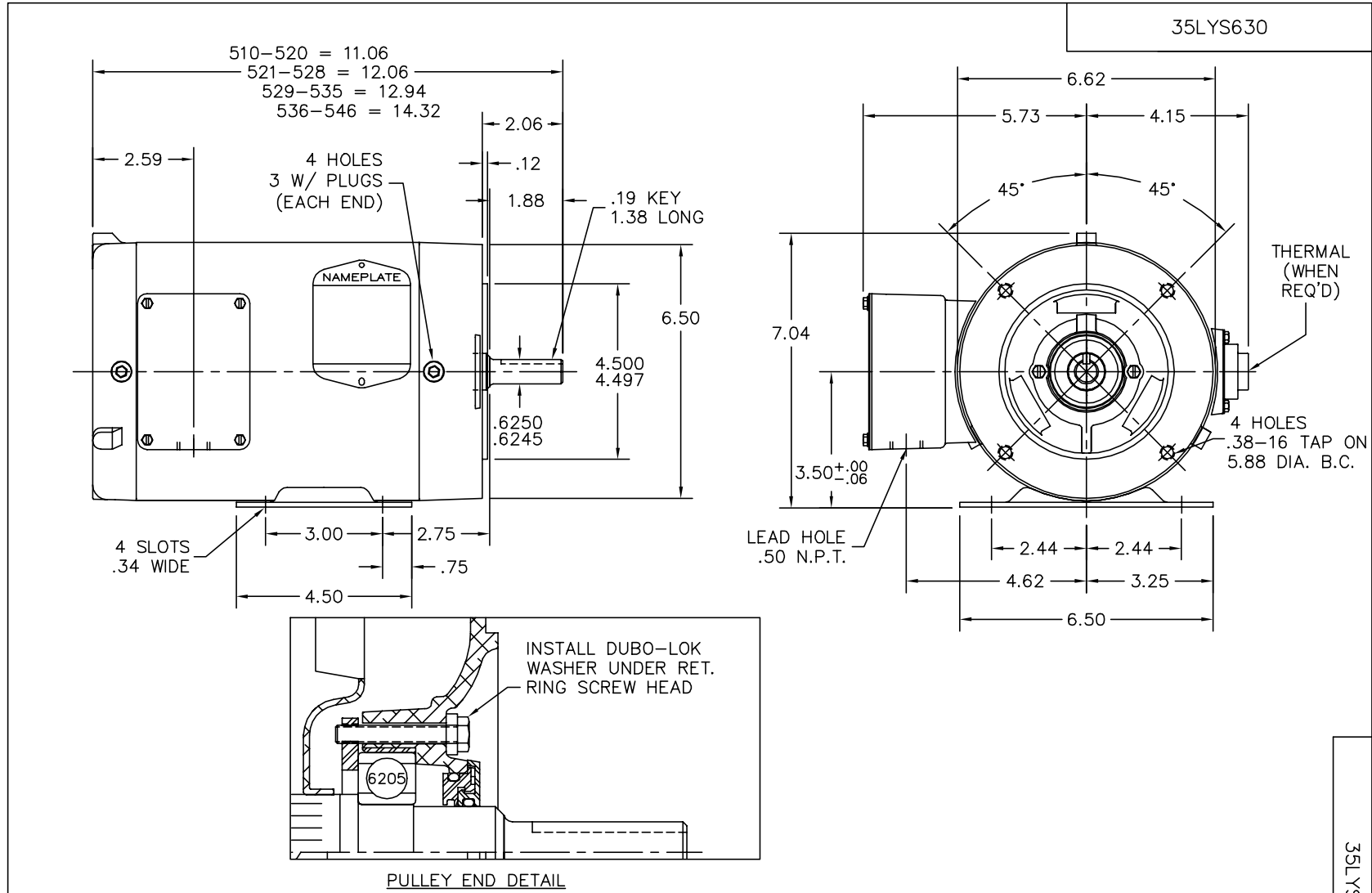

CUSTOMER IS RESPONSIBLE FOR DETERMINING THAT BALDOR'S PRODUCT WILL PERFORM SUITABLY IN THE INTENDED APPLICATION.

REV. DESC: REVISE DESCRIPTION			
REV. LTR: C	VERSION: 03	TDR: 000000528123	
FILE: \AAA\00093\228		REVISED: 08:34:21 02/11/2010	
MTL: -		BY: ENBRAMO	

BALDOR • DODGE • RELIANCE

STD HORZ 56C TENV 35M WD2 (PAINT FREE)

SH 1 of 1

35LYS630

CD0005



LOW VOLTAGE
(2Y)



LINE

HIGH VOLTAGE
(1Y)

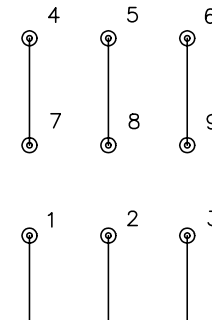

LINE

NOTES:

1. INTERCHANGE ANY TWO LINE LEADS TO REVERSE ROTATION.
2. OPTIONAL THERMOSTATS ARE PROVIDED WHEN SPECIFIED.
3. ACTUAL NUMBER OF INTERNAL PARALLEL CIRCUITS MAY BE A MULTIPLE OF THOSE SHOWN ABOVE.
4. LEAD COLORS ARE OPTIONAL. LEADS MUST ALWAYS BE NUMBERED AS SHOWN.

REV. DESC: REVISE TO SHOW OPTIONAL COLORS			
REV. LTR: E	BY: JLP	REVISED: 01/19/99 10:15	TDR: 0171435
900000		FILE: AAA00005140	MDL: -
		MTL: -	

BALDOR ELECTRIC Co.

3PH, DV, 9 LEADS

CD0005