

BALDOR® • RELIANCE 

Product Information Packet

JMEWDM3711T

10HP,3450RPM,3PH,60HZ,215JM,3736M,TEFC,F

Part Detail							
Revision:	K	Status:	PRD/A	Change #:		Proprietary:	No
Type:	AC	Elec. Spec:	37WGR697	CD Diagram:	CD0005	Mfg Plant:	
Mech. Spec:	37H883	Layout:	37LYH883	Poles:	02	Created Date:	12-04-2014
Base:	RG	Eff. Date:	07-18-2019	Leads:	9#14		

Specs			
Catalog Number:	JMEWDM3711T	Heater Indicator:	No Heater
Enclosure:	TEFC	Insulation Class:	F
Frame:	215JM	Inverter Code:	Inverter Ready
Frame Material:	Steel	KVA Code:	H
Output @ Frequency:	10.000 HP @ 60 HZ	Lifting Lugs:	Standard Lifting Lugs
Synchronous Speed @ Frequency:	3600 RPM @ 60 HZ	Locked Bearing Indicator:	Locked Bearing
Voltage @ Frequency:	208.0 V @ 60 HZ	Motor Lead Quantity/Wire Size:	9 @ 14 AWG
	460.0 V @ 60 HZ	Motor Lead Exit:	Ko Box
	230.0 V @ 60 HZ	Motor Lead Termination:	Flying Leads
XP Class and Group:	None	Motor Type:	3736M
XP Division:	Not Applicable	Mounting Arrangement:	F1
Agency Approvals:	CSA	Power Factor:	96
	CSA EEV	Product Family:	Wash Down
	UR	Pulley End Bearing Type:	Sealed Bearing
Auxillary Box:	No Auxillary Box	Pulley Face Code:	C-Face
Auxillary Box Lead Termination:	None	Pulley Shaft Indicator:	Tapped & Key
Base Indicator:	Rigid	Rodent Screen:	None
Bearing Grease Type:	Polyrex EM (-20F +300F)	Shaft Extension Location:	Pulley End

Blower:	None	Shaft Ground Indicator:	No Shaft Grounding
Current @ Voltage:	24.000 A @ 208.0 V	Shaft Rotation:	Reversible
	21.600 A @ 230.0 V	Shaft Slinger Indicator:	Shaft Slinger
	10.800 A @ 460.0 V	Speed Code:	Single Speed
Design Code:	B	Motor Standards:	NEMA
Drip Cover:	No Drip Cover	Starting Method:	Direct on line
Duty Rating:	CONT	Thermal Device - Bearing:	None
Electrically Isolated Bearing:	Not Electrically Isolated	Thermal Device - Winding:	None
Feedback Device:	NO FEEDBACK	Vibration Sensor Indicator:	No Vibration Sensor
Front Face Code:	Standard	Winding Thermal 1:	None
Front Shaft Indicator:	None	Winding Thermal 2:	None

Nameplate NP1669L										
CAT.NO.	JMEWDM3711T									
SPEC.	37H883R697G1									
HP	10									
VOLTS	208-230/460									
AMP	24-21.6/10.8									
RPM	3450									
FRAME	215JM				HZ	60			PH	3
SER.F.	1.15		CODE	H	DES	B		CLASS	F	
NEMA-NOM-EFF	90.2		PF	96						
RATING	40C AMB-CONT									
CC	010A				USABLE AT 208V			24		
DE	6309				ODE	6206				
ENCL	TEFC			SN						
BLANK										

Parts List		
Part Number	Description	Quantity
SA290726	SA 37H883R697G1	1.000 EA
RA276882	RA 37H883R697G1	1.000 EA
HW3200A01	3/8-16X3/4 I-BLT WELDED F/S	1.000 EA
37CB3005A04W	CASTING W/.75 NPT@6(MACH WHITE)	1.000 EA
37GS1025	37 MOLDED GASKET W/LIP, LEAD SEAL	1.000 EA
51XW2520A12	.25-20 X .75, TAPTITE II, HEX WSHR SLTD	2.000 EA
HA5027A01	HA4066A01 T-DRAIN X2 BAGGED	1.000 EA
11XW1032G06	10-32 X .38, TAPTITE II, HEX WSHR SLTD U	1.000 EA
37EP3101A94MW	FRONT TEFC L&M 206 BRG W/O GR SR (WHITE)	1.000 EA
HW5100A06	W2420-025 WVY WSHR (WB)	1.000 EA
37EP3401T08MW	FACE MT EP, ENCL, 213TC-215TC, W/WHITE E	1.000 EA
HW4032A01	BLACK DRAIN PLUG FOR WASH DOWN MOTORS	3.000 EA
HW4032A01	BLACK DRAIN PLUG FOR WASH DOWN MOTORS	3.000 EA
10XN2520S36	1/4-20X 2 1/4 HEX HD SS	4.000 EA
XY3118S12	5/16-18 HEX NUT, STAINLESS STEEL	4.000 EA
07FH4011	WASHDOWN IEC FH W/PRIMED	1.000 EA
11XW1032S06	SCREW, HXWSHR HD SLDTYF 410 SS	3.000 EA
HW4600B53	SEAL 1.688 X 2.275 X 0.312 SINGLE LIP DB	1.000 EA
HW4600B74	V-RING SLINGER 1.125 X 1.445 X .24 VITON	1.000 EA
HW4600B67	V-RING SLINGER 1.770 X 2.170 X .28 VITON	1.000 EA
37CB4512	CONDUIT BOX LID FOR WASHDOWN 37 FRAME	1.000 EA
37GS1008A02	37 GS FOR CB LID - WHITE NEOPRENE	1.000 EA
59XN0832S07	8/32 X 7/16 HX WS HD SER X	4.000 EA
HW2502D13	SS KEY, 3/16 SQ X 1.375	1.000 EA

Parts List (continued)		
Part Number	Description	Quantity
HA7000A01	KEY RETAINER 7/8" DIA SHAFT	1.000 EA
MJ5001A27	32220KN GRAY SEALER *MIN BUY 4 QTS=1GAL	0.001 QT
85XU0407S04	4X1/4 U DRIVE PIN STAINLESS	2.000 EA
LB1164	LABEL,WARNING AND DRAIN	1.000 EA
LB1115N	LABEL,LIFTING DEVICE (ON ROLLS)	1.000 EA
MJ1000A02	GREASE, MOBIL POLYREX EM - 124047	0.050 LB
37FN3002A01SP	EXFN, PLASTIC, 9.00 OD, 1.155 ID	1.000 EA
51XB1214A20	12-14X1.25 HXWSSLD SERTYB	1.000 EA
MG1025Z02	ACTIVATOR WILKOFAS 060.02HF	0.010 GA
MG1025W01	WILKOFAS 781.01, SIGNAL WHITE #9003	0.028 GA
HA3104S17	THRUBOLT 13.250LG SS	4.000 EA
LC0005	CONN.DIA.,TY M,9-LD,DUAL VOLT,REVERSING	1.000 EA
MN416A01	TAG-INSTAL-MAINT no wire (1200/bx) 3/19	1.000 EA
NP1669L	SS WD SUPER-E UL CSA-EEV PREM REV MTG	1.000 EA
G0PA1000	PKG GRP, PRINT PK1026A06	1.000 EA

AC Induction Motor Performance Data

Record # 48426 - Typical performance - not guaranteed values

Winding: 37WGR697-R001	Type: 3736M	Enclosure: TEFC
-------------------------------	--------------------	------------------------

Nameplate Data				460 V, 60 Hz: High Voltage Connection	
Rated Output (HP)	10			Full Load Torque	15.1 LB-FT
Volts	208-230/460			Start Configuration	direct on line
Full Load Amps	24-21.6/10.8			Breakdown Torque	58.2 LB-FT
R.P.M.	3450			Pull-up Torque	24.1 LB-FT
Hz	60	Phase	3	Locked-rotor Torque	33.7 LB-FT
NEMA Design Code	B	KVA Code	H	Starting Current	81.7 A
Service Factor (S.F.)	1.15			No-load Current	2.59 A
NEMA Nom. Eff.	90.2	Power Factor	96	Line-line Res. @ 25°C	1.03 Ω
Rating - Duty	40C AMB-CONT			Temp. Rise @ Rated Load	59°C
S.F. Amps				Temp. Rise @ S.F. Load	74°C
				Locked-rotor Power Factor	32.3
				Rotor inertia	0.329 LB-FT ²

Load Characteristics 460 V, 60 Hz, 10 HP

% of Rated Load	25	50	75	100	125	150	S.F.
Power Factor	74	91	94	96	96	94	96
Efficiency	87	91	91.3	90.6	89.9	88.3	90.2
Speed	3569	3542	3512	3480	3447	3408	3460
Line amperes	3.73	5.77	8.25	10.8	13.5	16.8	12.4

Performance Graph at 460V, 60Hz, 10.0HP Typical performance - Not guaranteed values

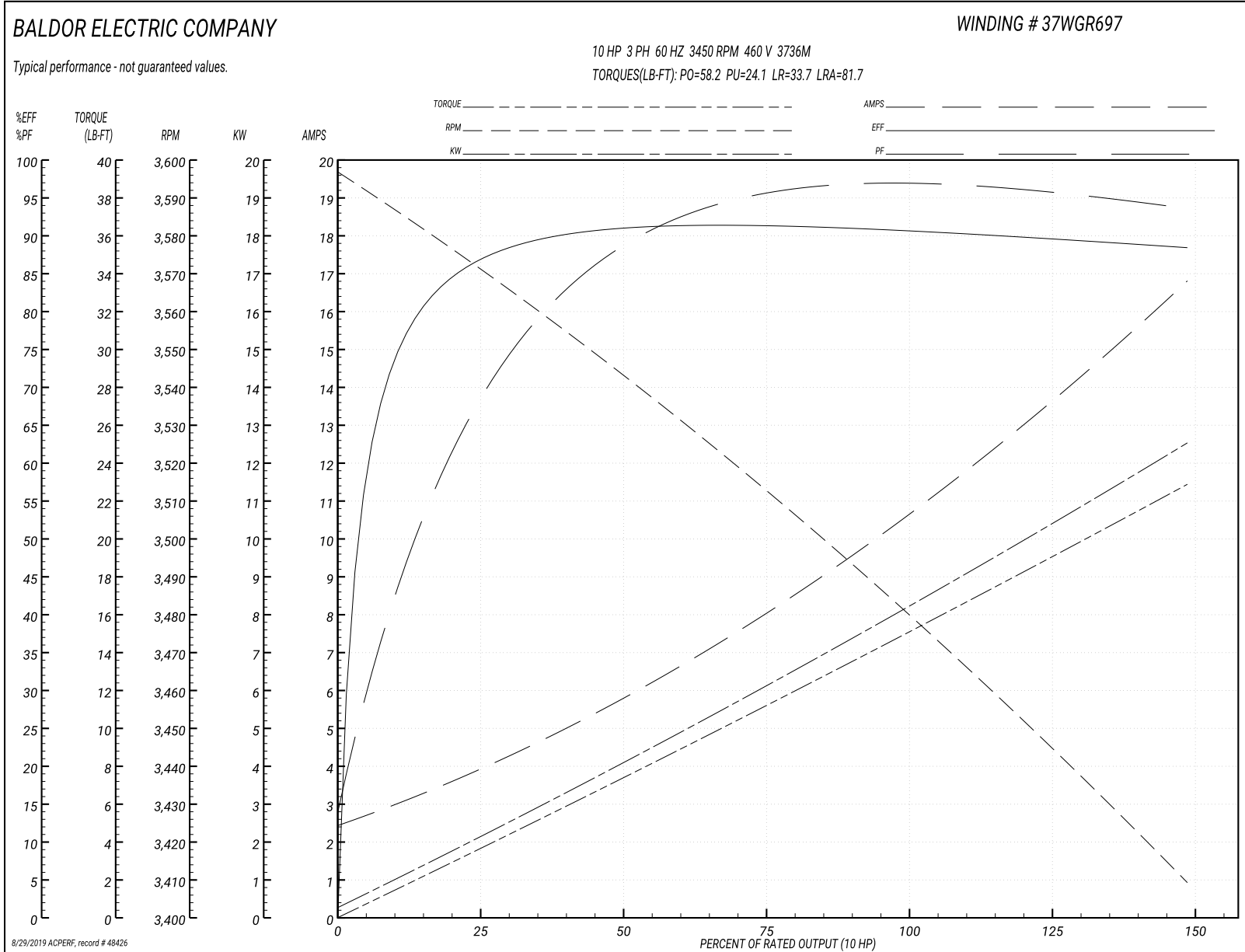

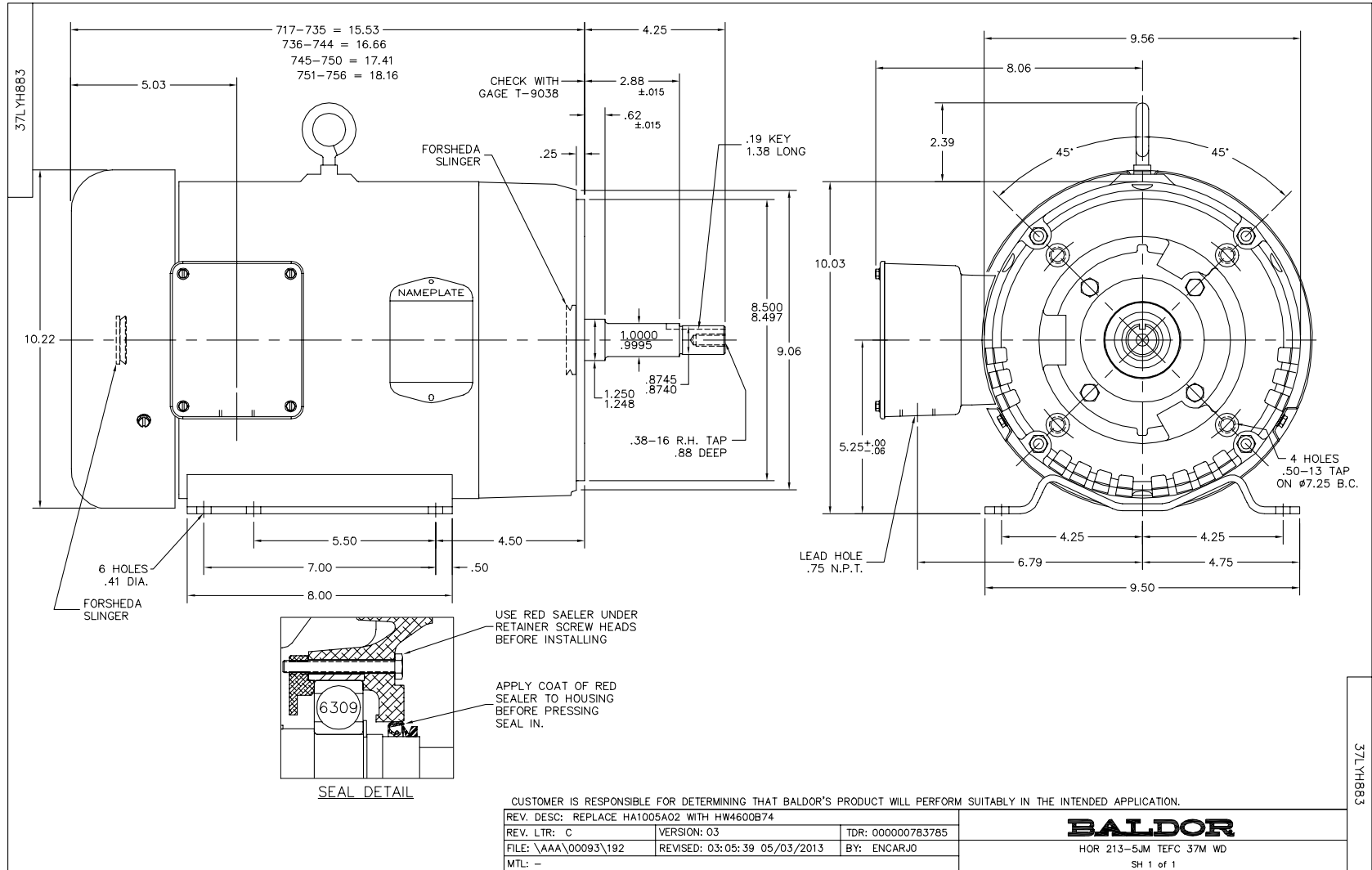

CD0005



LOW VOLTAGE
(2Y)



LINE

HIGH VOLTAGE
(1Y)

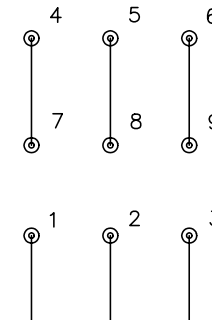

LINE

NOTES:

1. INTERCHANGE ANY TWO LINE LEADS TO REVERSE ROTATION.
2. OPTIONAL THERMOSTATS ARE PROVIDED WHEN SPECIFIED.
3. ACTUAL NUMBER OF INTERNAL PARALLEL CIRCUITS MAY BE A MULTIPLE OF THOSE SHOWN ABOVE.
4. LEAD COLORS ARE OPTIONAL. LEADS MUST ALWAYS BE NUMBERED AS SHOWN.

REV. DESC: REVISE TO SHOW OPTIONAL COLORS			
REV. LTR: E	BY: JLP	REVISED: 01/19/99 10:15	TDR: 0171435
90000		FILE: AAA00005140	MDL: -
		MTL: -	

BALDOR ELECTRIC Co.

3PH, DV, 9 LEADS

CD0005