

BALDOR® • **RELIANCE**

Product Information Packet

IDVSM44304T-4

300HP, 1790-2685RPM, 3PH, 60-90HZ, 449T, A441

Part Detail							
Revision:	H	Status:	PRD/A	Change #:		Proprietary:	No
Type:	AC	Elec. Spec:	A44WG0622	CD Diagram:	416820-036	Mfg Plant:	
Mech. Spec:		Layout:	617427-003	Poles:	04	Created Date:	08-24-2012
Base:		Eff. Date:	09-07-2017	Leads:	3#1 (04 per group)		

Specs			
Catalog Number:	IDVSM44304T-4	Duty Rating:	CONT
Enclosure:	TEFC	Feedback Device:	NO FEEDBACK
Frame:	449T	Heater Indicator:	No Heater
Frame Material:	Iron	Insulation Class:	F
Output @ Frequency:	300.000 HP @ 90 HZ	Inverter Code:	Inverter Duty
	300.000 HP @ 60 HZ	KVA Code:	M
Synchronous Speed @ Frequency:	1800 RPM @ 60 HZ	Lifting Lugs:	Standard Lifting Lugs
Voltage @ Frequency:	460.0 V @ 60 HZ	Motor Lead Quantity/Wire Size:	12 @ 1 AWG
	460.0 V @ 90 HZ	Motor Type:	A44160M
XP Class and Group:	None	Mounting Arrangement:	F1
XP Division:	Not Applicable	Power Factor:	86
Agency Approvals:	CCSA US	Pulley End Bearing Type:	Ball
Auxillary Box:	No Auxillary Box	Pulley Face Code:	Standard
Base Indicator:	Rigid	Shaft Ground Indicator:	No Shaft Grounding
Bearing Grease Type:	Polyrex EM (-20F +300F)	Shaft Rotation:	Reversible
Constant Torque Speed Range:	1000:1	Shaft Slinger Indicator:	No Slinger
Current @ Voltage:	322.000 A @ 460.0 V	Speed Code:	Single Speed
	338.000 A @ 460.0 V	Motor Standards:	NEMA

Design Code:	A	Starting Method:	Direct on line
Drip Cover:	No Drip Cover	Thermal Device - Bearing:	None
		Thermal Device - Winding:	None

Nameplate 000613007HV									
CAT NO	IDVSM44304T-4			SPEC NO.	P44G4012				
SER.NO.				FRAME	449T				
	HP		RPM		VOLTS		AMPS	HZ	TYPE P
BASE	300	1790	460	338	60	SF	1.00		
MAX	300	2685	460	322	90			INSUL.CLASS	F
DRIVE END BEARING	90BC03J30X			CONSTANT TORQUE	DUTY		CONT	AMB	40
OPP D.E. BEARING	6318C3VL0241			1000:1	ENCL	TEFC		PHASE	3
DESIGN NO.	A44WG0622-R002			FLUX AMPS	116				
MAX SPEED/RPM	3600			OVERTEMP PROT	2	WK2	105	POLES	4
								WEIGHT	

Parts List		
Part Number	Description	Quantity
SA254362	SA P44G4012	1.000 EA
RA241170	RA P44G4012	1.000 EA
000692000FF	N/P	1.000 EA
000692000VD	LABEL WARNING	1.000 EA
000613007HV	N/P BALDOR VSMaster	1.000 EA
421948051	LABEL, MYLAR	1.000 EA
004824015A	GREASE POLYREX EM	1.160 LB
032018008CK	HHCS 3/8-16X1L PLATED	4.000 EA
032018020FK	HHCS 3/4-10X2-1/2 PLTD.	4.000 EA
032018030DK	HHCS 1/2-13X3-3/4 PLTD.	3.000 EA
032018030DK	HHCS 1/2-13X3-3/4 PLTD.	3.000 EA
032620016LA	SOCKET SET SCREW-449	3.000 EA
034017014AB	LCKW 3/8 STD. PLATED	4.000 EA
034180014DA	KEY 1/4X1/4X1-3/4 L	1.000 EA
034530072AB	P/NIP 1/8X9"L Threaded both ends	1.000 EA
035000001A	ALFTG 1/8" 1610-BL	1.000 EA
035000001A	ALFTG 1/8" 1610-BL	1.000 EA
034690002AB	"unbulked" PPLG 1/4" PLTD.	1.000 EA
034690005AB	PPLG 3/4 PLATED	2.000 EA
034690001AB	SQHDPLG, COND	1.000 EA
089490099A	G28 BRKT 089490098WCA KB	1.000 EA
702618004T	FAN KB 182/70 (112) 440	1.000 EA
083199082A	G28 FAN COVER MACHINING SHORT VERSION	1.000 EA
089490099A	G28 BRKT 089490098WCA KB	1.000 EA

Parts List (continued)		
Part Number	Description	Quantity
410700004A	WSHR	1.000 EA
415072001B	CLAMP	1.000 EA
415096002A	CPLG 1/8 HEX TYPE	1.000 EA
032018004BK	HHCS 5/16-18X1/2 PLATED	3.000 EA
032018006BK	HHCS 5/16-18X3/4 PLATED	3.000 EA
702623022A	G28 AIR DEFLECTOR DRIVE END -- PLASTIC	1.000 EA
032018020FK	HHCS 3/4-10X2-1/2 PLTD.	4.000 EA
034017013AB	LCKW 5/16 STD. PLATED	3.000 EA
034530072AB	P/NIP 1/8X9"L Threaded both ends	1.000 EA
034690002AB	"unbulked" PPLG 1/4" PLTD.	1.000 EA
034690001AB	SQHDPLG, COND	1.000 EA
415096002A	CPLG 1/8 HEX TYPE	1.000 EA
418151014G	RETAIN RING	1.000 EA
702623013A	THERMAL BARRIER -- G28 -- BRACKET MTD	1.000 EA
032018008DK	HHCS 1/2-13X1 PLATED	4.000 EA
415915007G	GASK, LAC	1.000 FT
033512004LB	HHTTS 1/4-20X1/2 PLTD.	1.000 EA
033512006LB	HHTTS 1/4-20X3/4 PLTD.	8.000 EA
406056008A	GASKET, TERBD 440	1.000 EA
406099000A	PLUG - FAN COVER 320-440	1.000 EA
415000103D	T/LUG #4AWG-1/0AWG W/HOLE FOR .250 BOLT	1.000 EA
418153001A	GASK 440	1.000 EA
702658001B	+C/BOX, PAINTED 440	1.000 EA
702658002A	+C/BOX CVR, PAINTED 440	1.000 EA

Product Information Packet: IDVSM44304T-4 - 300HP,1790-2685RPM,3PH,60-90HZ,449T,A441

033775004EA	DRSCR #6-1/4 304 S.S.	2.000 EA
034180054KA	KEY 7/8X7/8X6-3/4 L	1.000 EA
N424001803DBF	LEAD SET 1-1 AWG 6-DB 447/9 FR 102 IN	2.000 EA
PK5005A01	WOOD BASE 449 60 X 41-1/2 BLT 25 X 18	1.000 EA
MG1025N19	WILKO 778.50 BLUE GREEN - 55 GAL DRUMS	0.500 GA

REL. S. O. -
 FRAME 449T
 HP 300
 BASE SPEED 1790
 PHASE/HERTZ 3/60

VOLTS 460
 AMPS 338
 DUTY 1.00
 S.F. 1.00
 AMB °C/INSUL 40/F

ENCLOSURE 3600
 MAX SAFE RPM 3600
 IM (AMPS) 116
 P.F. @NL/FL .047/.863
 WK² (LB-FT²) 105.12

TEFC
 WYE CONN EQ CKT OHMS PER PHASE (AT BASE RATING, 25 °C)
 R1 .00400 X1 .0537
 R2 .00288 X2 .0606
 XM 1.93

RATED FULL LOAD DATA

	RPM	HP	TORQUE LB-FT	FUND VOLTS	FREQ-HZ	AMPS
BASE SPEED	1791	300	880	460	60	338
MAX SPEED	2687	300	586	460	90	323
MIN SPEED	0	0	880	5.83	.284	338

LOAD PERFORMANCE AT BASE SPEED

	RPM	HP	TORQUE LB-FT	FUND VOLTS	FREQ-HZ	AMPS
NO LOAD	1800	0	0	460	60	116
1/4	1798	75.2	220	460	60	158
1/2	1796	150	439	460	60	208
3/4	1794	225	659	460	60	269
FULL LOAD	1791	300	880	460	60	338
O/L	1782	597	1760	460	60	645

BLOWER DATA

VOLTS	PH/HZ	FL AMPS	LR AMPS	FRAME	CFM

REMARKS: TYPICAL DATA
 VECTOR PWM INVERTER DUTY

BALDOR	DR. BY J. J. HARRISON	A-C MOTOR PERFORMANCE DATA
	CK. BY W. L. SMITH	
	APP. BY W. L. SMITH	A44WG0622-R002
	DATE 08/17/04	
		ISSUE DATE 12/17/10

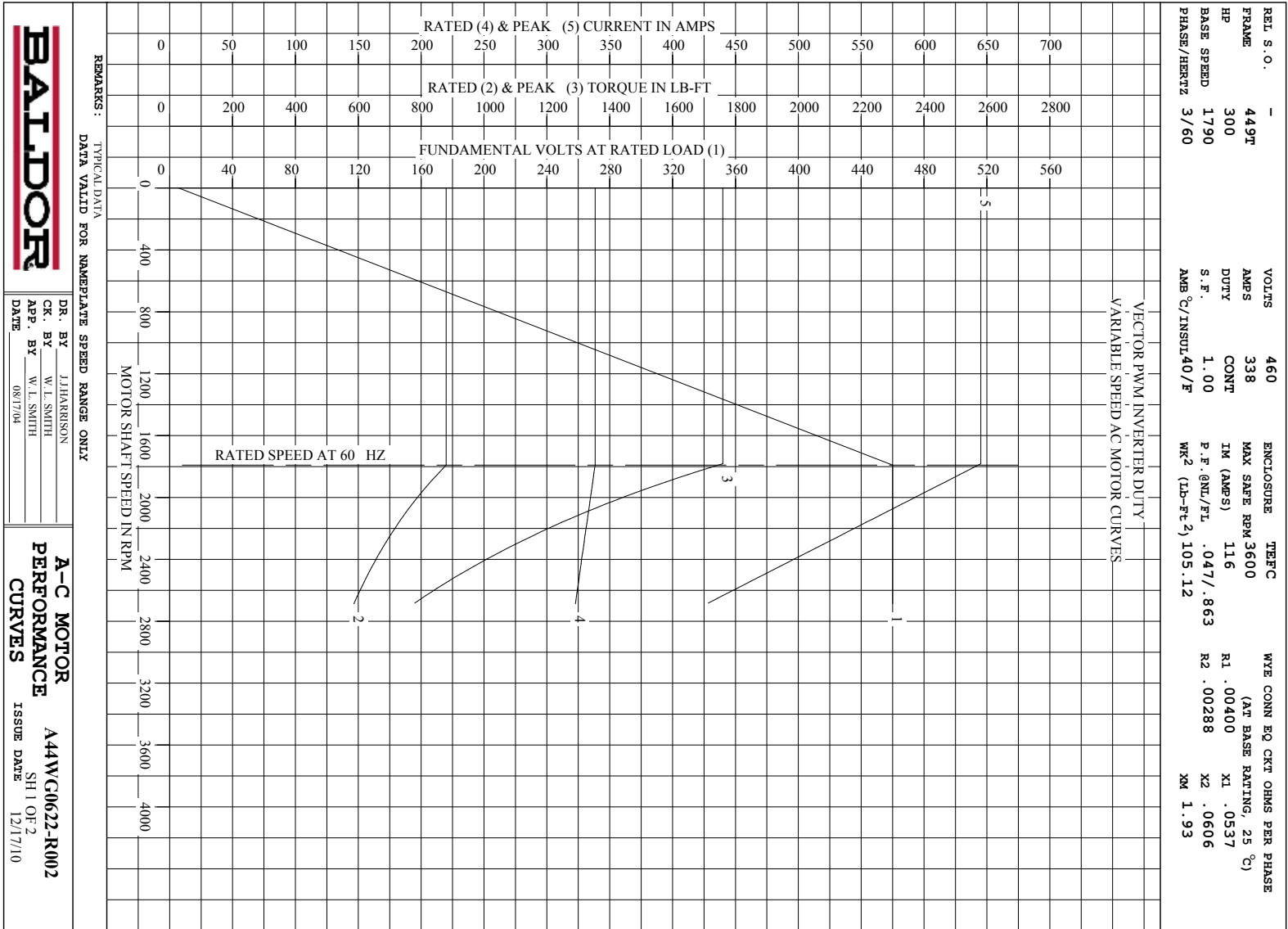

DR. BY J. HARRISON
 CK. BY W. L. SMITH
 APP. BY W. L. SMITH
 DATE 08/17/04

A-C MOTOR PERFORMANCE CURVES
 A44WG0622-R002
 SH 1 OF 2
 ISSUE DATE 12/17/10

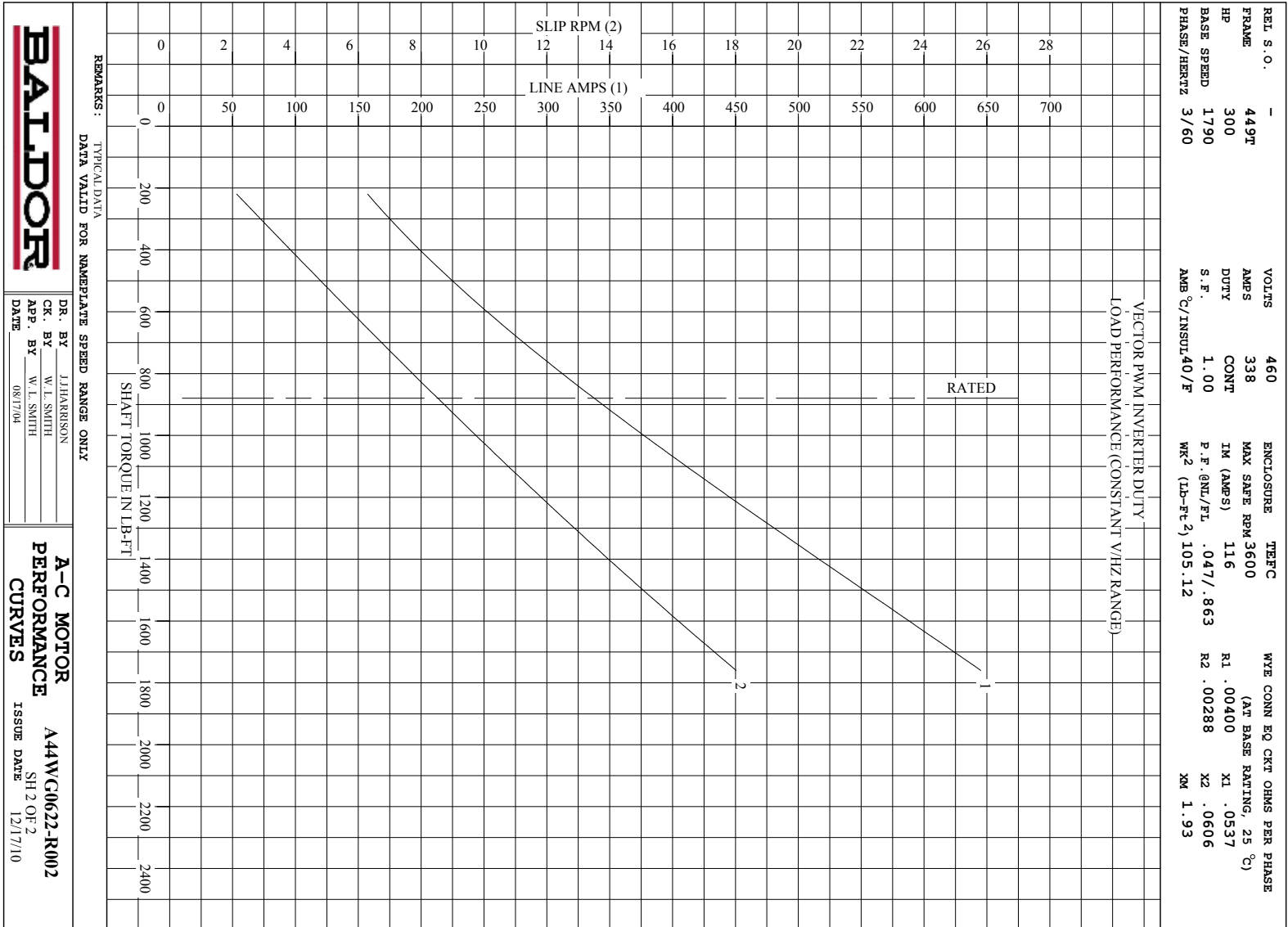

DR. BY J.J. HARRISON
 CK. BY W.L. SMITH
 APP. BY W.L. SMITH
 DATE 08/17/04

A-C MOTOR PERFORMANCE CURVES
 A44WG0622-R002
 SH 2 OF 2
 ISSUE DATE 12/17/10

617427-003

DUTY MASTER ALTERNATING CURRENT MOTORS

SQUIRREL-CAGE INDUCTION

ENCLOSURE: TOTALLY ENCLOSED

FRAME 449T ABOVE NEMA RATINGS (1800 RPM MAX)

COOLING: FAN COOLED

MOUNTING: FOOT

INCLUDES 447T FRAME MOUNTING HOLES

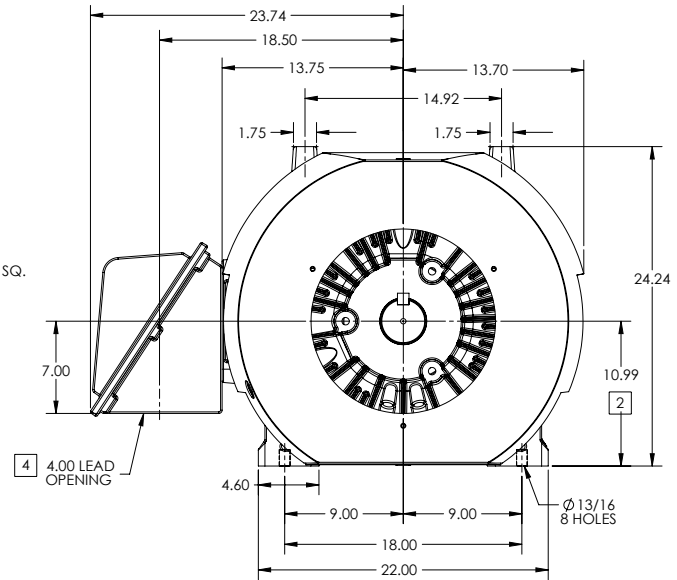
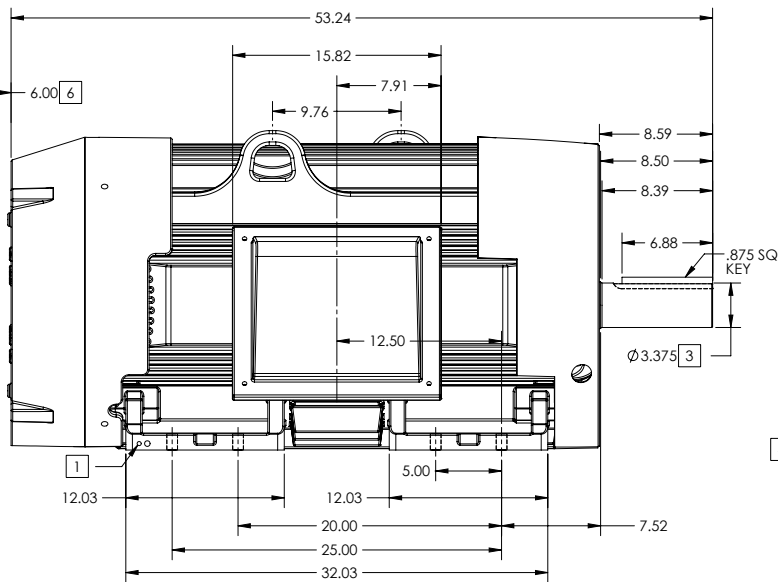

1. GROUND HOLES QTY 1 1/2-13 TAP; QTY 1 3/8-16 TAP
2. VARIES +.00,-.06
3. VARIES +.00,-.001
4. ON STANDARD MOTORS THIS IS CONDUIT SIZE. ON XT AND CORROSION PROOF MOTOR THIS IS PIPE TAP.
5. MOTOR WEIGHTS MAY VARY BY 1.5% DEPENDING ON RATING.
6. OBSTRUCTION MUST NO ENCROACH ON AIR INLET

CONDUIT BOX LOCATED ON OPPOSITE SIDE WHEN F-2.
IF MOUNTING CLEARANCE DETAILS ARE REQUIRED, CONSULT FACTORY.
MAXIMUM PERMISSIBLE SHAFT RUNOUT WHEN MEASURED AT END OF STANDARD SHAFT EXTENSION IS .003" T.I.R. TO 5 INCH DIA.

5 WEIGHT (LBS): 3080

DRIVE END AIR DEFLECTOR IS ONLY INCLUDED WHEN NECESSARY.

DIMENSIONS ARE IN INCHES; SEE SHEET 2 FOR DIMENSIONS IN MILLIMETERS

CUSTOMER IS RESPONSIBLE FOR DETERMINING THAT MOTOR PERFORMANCE IS SUITABLE IN THE APPLICATION.

SHEET NUMBER
1 OF 2

E007-L27-119

REV. DESC: NEW DRAWING	VERSION: 02	REVISED: 11.32.36 10/23/2017	TDR: 000001048162
MODEL NO. 617427-003	BY: RAGRA		

BALDOR

G449T-447T STD - FOOTED - SIDE CENTER CB

617427-003

617427-003

DUTY MASTER ALTERNATING CURRENT MOTORS

SQUIRREL-CAGE INDUCTION

ENCLOSURE: TOTALLY ENCLOSED

FRAME 449T ABOVE NEMA RATINGS (1800 RPM MAX)

COOLING: FAN COOLED

MOUNTING: FOOT

INCLUDES 447T FRAME MOUNTING HOLES

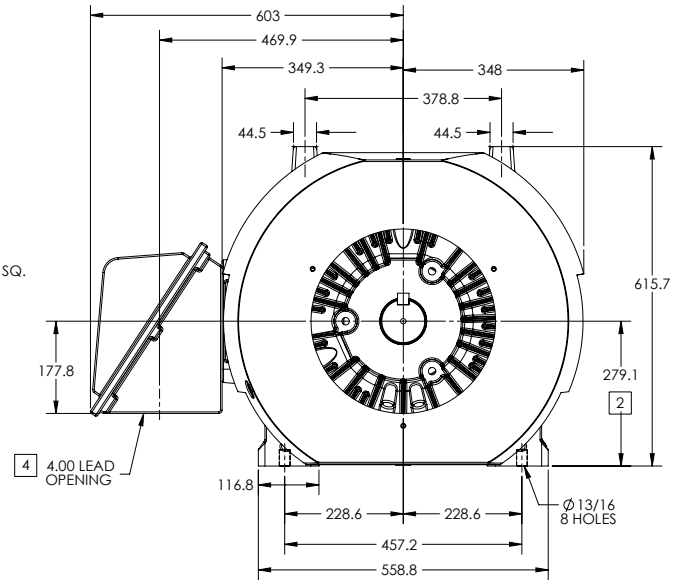
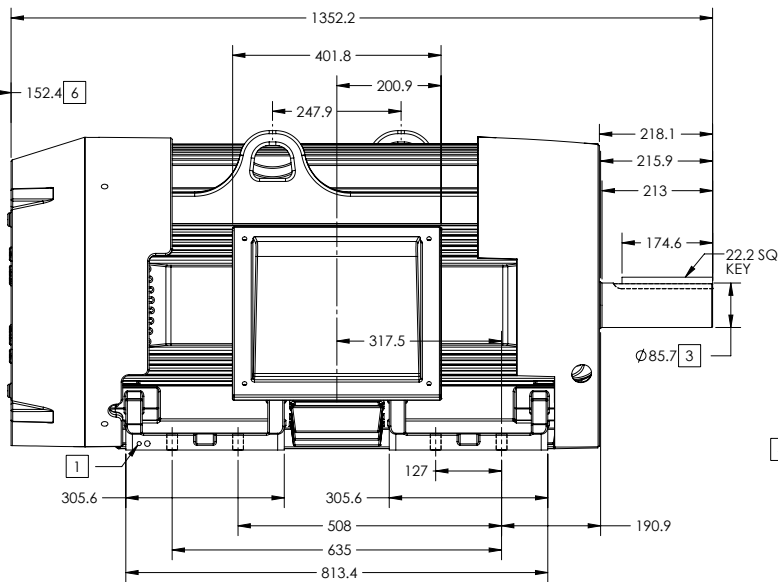

1. GROUND HOLES QTY 1 1/2-13 TAP; QTY 1 3/8-16 TAP
2. VARIES +.00,-.06
3. VARIES +.000,-.001
4. ON STANDARD MOTORS THIS IS CONDUIT SIZE. ON XT AND CORROSION PROOF MOTOR THIS IS PIPE TAP.
5. MOTOR WEIGHTS MAY VARY BY 15% DEPENDING ON RATING.
6. OBSTRUCTION MUST NO ENCROACH ON AIR INLET

CONDUIT BOX LOCATED ON OPPOSITE SIDE WHEN F-2.
IF MOUNTING CLEARANCE DETAILS ARE REQUIRED, CONSULT FACTORY.
MAXIMUM PERMISSIBLE SHAFT RUNOUT WHEN MEASURED AT END OF STANDARD SHAFT EXTENSION IS .08 MM T.I.R. TO 127 MM DIA.

5 WEIGHT (KGS): 1400

DRIVE END AIR DEFLECTOR IS ONLY INCLUDED WHEN NECESSARY.

DIMENSIONS ARE IN MILLIMETERS; SEE SHEET 1 FOR DIMENSIONS IN INCHES

CUSTOMER IS RESPONSIBLE FOR DETERMINING THAT MOTOR PERFORMANCE IS SUITABLE IN THE APPLICATION.

SHEET NUMBER
2 OF 2

E00-LZF119

REV. DESC: NEW DRAWING	VERSION: 02	REVISED: 11/32/36 10/23/2017	TDR: 000001048162
MODEL NO. 617427-003	BY: RAGRA		

BALDOR

G449T-447T STD - FOOTED - SIDE CENTER CB

617427-003

416820-036

A-C MOTOR
 CONNECTION DIAGRAM
 STANDARD 3 LEAD CONNECTED

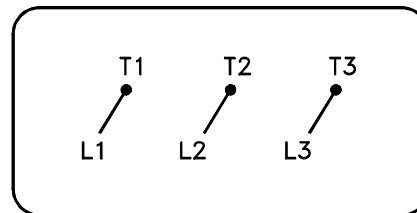

(N.P. 1575-BA)

416820-036

REV. DESC: LOADED TO BUS, C/R 335225		
REV. LTR: -	VERSION: 00	TDR: 000000538207
FILE: \MGA\00000\682	REVISED: 11:54:06 04/30/2010	
MTL: -	BY: RAGRA	

BALDOR

CONN DIAG - STANDARD 3 LEAD

SH 1 of 1