

BALDOR® • ***RELIANCE***

Product Information Packet

1022WD

1HP, 1800RPM, 1PH, 60HZ, 3528C, GRND

Part Detail							
Revision:	AW	Status:	PRD/A	Change #:		Proprietary:	No
Type:	AC	Elec. Spec:	G0WG0002	CD Diagram:	CD0279	Mfg Plant:	
Mech. Spec:	G10-237	Layout:	G0LY0237	Poles:	04	Created Date:	
Base:	RG	Eff. Date:	12-01-2016	Leads:	4#18 SEE NOTES		Y

Specs			
Nameplate Output:	1		
Product Style:	GRINDER		

Nameplate NP3118	
CAT.NO.	1022WD
HP	1
PHASE	1
HZ	60
SER.NO.	
SPEC.	G10-237-2
	VOLTS 115/230
	AMPS 5.4/2.7
	RPM 1800

Parts List		
Part Number	Description	Quantity
SA037590	SA G10-237-2	1.000 EA
RA033615	RA G10-237-2	1.000 EA
OC3012F12SP	CYL OIL CAP 12MFD/370V	1.000 EA
G8BA3000A06	BASE, MACH	1.000 EA
19XX2510A14	1/4-10 X 7/8 HEX HD PLASTITE SCREW	4.000 EA
HW1000A25	1/4 SAE FLAT WASHER (FS)	4.000 EA
HW1003A50	LOCKWASHER,1/2",EXT.TOOTHZINC PLATED	1.000 EA
HA6053A01ZP	CLAMP, CAPACITOR 2" DIA, WHITE ZINC PLAT	1.000 EA
51XN1032A04	10-32 X 0.25 HX WS SL SR	2.000 EA
XY1032A02	10-32 HEX NUT DIRECTIONAL SERRATION	2.000 EA
G8CB4500A02	G8-272 BASE COVER,STPD X PLATED	1.000 EA
51XW0832A07	8-32 X .44, TAPTITE II, HEX WSHR SLTD SE	2.000 EA
RM1005A01SP	BUMPER- #2089 (R-R CO)	4.000 EA
15XF1032A10	10-32X5/8 PIN HD PHL TY FSEE JT	4.000 EA
G8EP3900A01SP	ENDPLATE, MACH	1.000 EA
G8EP3900A01SP	ENDPLATE, MACH	1.000 EA
HW5100A06	W2420-025 WVY WSHR (WB)	1.000 EA
HW5100A06	W2420-025 WVY WSHR (WB)	1.000 EA
HA1000A34	DR2463A .02 BRG GUARD B N	2.000 EA
HA3100A14	THRUBOLT 10-32 X 7.875	4.000 EA
XY1032A02	10-32 HEX NUT DIRECTIONAL SERRATION	4.000 EA
G0FH1807A01SP	GUARD,LH,10"GRINDER	1.000 EA
19XW2520A16	SCREW,1/4-20X1 TAPTITE-II OR ROLOC 91	4.000 EA
G0FH1806A01	GUARD,RH,10"GRINDER	1.000 EA

Parts List (continued)		
Part Number	Description	Quantity
19XW2520A16	SCREW,1/4-20X1 TAPTITE-II OR ROLOC 91	4.000 EA
HA6101A01SP	SUPPORT, TOOL REST MACH	1.000 EA
10XN3816A20	3/8-16X1 1/4 HEX HD CAP	3.000 EA
HW1001A38	LOCKWASHER 3/8, ZINC PLT .688 OD, .382 I	3.000 EA
HW1000A38	WASHER, 3/8" FLAT, SAE Z/P	3.000 EA
HA6101A01SP	SUPPORT, TOOL REST MACH	1.000 EA
10XN3816A20	3/8-16X1 1/4 HEX HD CAP	3.000 EA
HW1001A38	LOCKWASHER 3/8, ZINC PLT .688 OD, .382 I	3.000 EA
HW1000A38	WASHER, 3/8" FLAT, SAE Z/P	3.000 EA
G8AP1003A01SP	TOOL REST	1.000 EA
10XN3816A20	3/8-16X1 1/4 HEX HD CAP	1.000 EA
HW1001A38	LOCKWASHER 3/8, ZINC PLT .688 OD, .382 I	1.000 EA
G8AP1003A01SP	TOOL REST	1.000 EA
10XN3816A20	3/8-16X1 1/4 HEX HD CAP	1.000 EA
HW1001A38	LOCKWASHER 3/8, ZINC PLT .688 OD, .382 I	1.000 EA
G0AP1002SP	SPARK BREAKER (PLATED)	1.000 EA
HW1000A38	WASHER, 3/8" FLAT, SAE Z/P	2.000 EA
10XN3816A16	3/8-16 X 1 HEX HD CAP SCREW	2.000 EA
HW1001A38	LOCKWASHER 3/8, ZINC PLT .688 OD, .382 I	2.000 EA
G0AP1002SP	SPARK BREAKER (PLATED)	1.000 EA
HW1000A38	WASHER, 3/8" FLAT, SAE Z/P	2.000 EA
10XN3816A16	3/8-16 X 1 HEX HD CAP SCREW	2.000 EA
HW1001A38	LOCKWASHER 3/8, ZINC PLT .688 OD, .382 I	2.000 EA
HA6100	WHEEL FLANGE, CAST	4.000 EA

Product Information Packet: 1022WD - 1HP,1800RPM,1PH,60HZ,3528C,GRND

HW3020E04	1/8 X 3/8 A GROOVE PIN (DRIV-LOCK #118	2.000 EA
G0AP3000A01	WHEEL, 10X1X7/8X36 GRIT	1.000 EA
B103	WHEEL, 10X1X7/8X60 GRIT	1.000 EA
XY8809A62SP	7/8-9 NUT L.H. HEX (NC)	1.000 EA
XY8809A12SP	7/8-9 NUT R.H. HEX (NC)	1.000 EA
G0FH1804A01	GUARD COVER,LH,10"GRINDER	1.000 EA
10XN2520A16	1/4-20 X 1 HEX HEAD CAP SCR, ZINC PLATED	4.000 EA
G0FH1805A01SP	GUARD COVER,RH,10"GRINDER	1.000 EA
10XN2520A16	1/4-20 X 1 HEX HEAD CAP SCR, ZINC PLATED	4.000 EA
WD4502A01A02	CONDUIT BOX W/KNOCKOUTS, FOR 7,8 & 10 GR	1.000 EA
51XB1016A06	10-16X3/8 HXWSSLD SERTYB	2.000 EA
WD4503A01	T&B 58 C 1, OUTLET BOX LID	1.000 EA
G7AP5006A01	G7-253(GA9-2)EYESHIELD KIT (QTY 2)	1.000 EA
G9AP5002A01	A-683 WATER POT .18 45809107	1.000 EA
GA25	TOOL TRAY ASSY	1.000 EA
HA6103A01	SUPPORT ARM, EYESHIELD (PLATED)	2.000 EA
10XN3118A16	5/16-18X1 HEX HD CAP	2.000 EA
HW1001A31	LOCKWASHER 5/16, ZINC PLT.591 OD, .319 I	2.000 EA
HA6094A01SP	CLAMP FOR SUPPORT ARM X PLATED	2.000 EA
WD4102A01	SR-6L-1 HEYCO STRN RELIEF OR 23MPO6L10 M	2.000 EA
85XU0407S04	4X1/4 U DRIVE PIN STAINLESS	2.000 EA
SP9000SP	80600BJ A-H OR 1520237-2 TYCO;2PST,125/2	1.000 EA
MJ1000A02	GREASE, POLYREX EM EXXON (USe 4824-15A)	0.050 LB
MG1000G01	MUNSELL 5.93PB 3.81/ 2.71 HF BATTLESHIP	0.017 GA
LC0279A01	1PH, DV, FIX, GRINDER, CONN FOR LV	1.000 EA
LB1119N	WARNING LABEL	1.000 EA

Product Information Packet: 1022WD - 1HP,1800RPM,1PH,60HZ,3528C,GRND

LB1389A01	CONSOLIDATED GRINDER LABEL - 9",10",12"	1.000 EA
NP3118	ALUM GRINDERS-BUFFERS NO LOGO'S	1.000 EA
07PA1007	PKG GRP, PRINT PK1156A06	1.000 EA
MN903	INSTR MANUAL FOR GRINDERS 9/03	1.000 EA

Accessories		
Part Number	Description	Multiplier
GA16	PEDESTAL INDUSTRIAL, CAST IRON 6" - 10"	
GA14	PEDESTAL FABRICATED STEEL W/SHELVES	
GA20	PEDESTAL INDUSTRIAL, CAST IRON 8"-14"	
GA20E	PEDESTAL LIGHT INDUSTRIAL,STEEL	
B102	10" 36 GRIT GRINDING WHEEL	
B103	10" 60 GRIT GRINDING WHEEL	
GA9	PAIR LIGHTED EYESHIELDS	
GA9-1	SINGLE LIGHTED EYESHIELD	
GA9S	PAIR EYESHIELDS W/ ON-OFF SWITCH	
GA11	PAIR EYESHIELDS	
DC10	DUST CONTROL UNIT	
BQ1-015-CC	1PH Brake, NEMA 1,110-125 VAC, 50/60Hz	
BQ1-015-CP	1PH Brake, Panel 110-125 VAC, 50/60 Hz	
BQ2-015-CC	1PH Brake,NEMA 1 208-230 VAC,50/60Hz	
BQ2-015-CP	1PH Brake, Panel 208-230 VAC, 50/60 Hz	

No performance data has been
assigned to this product.

GOLY0237

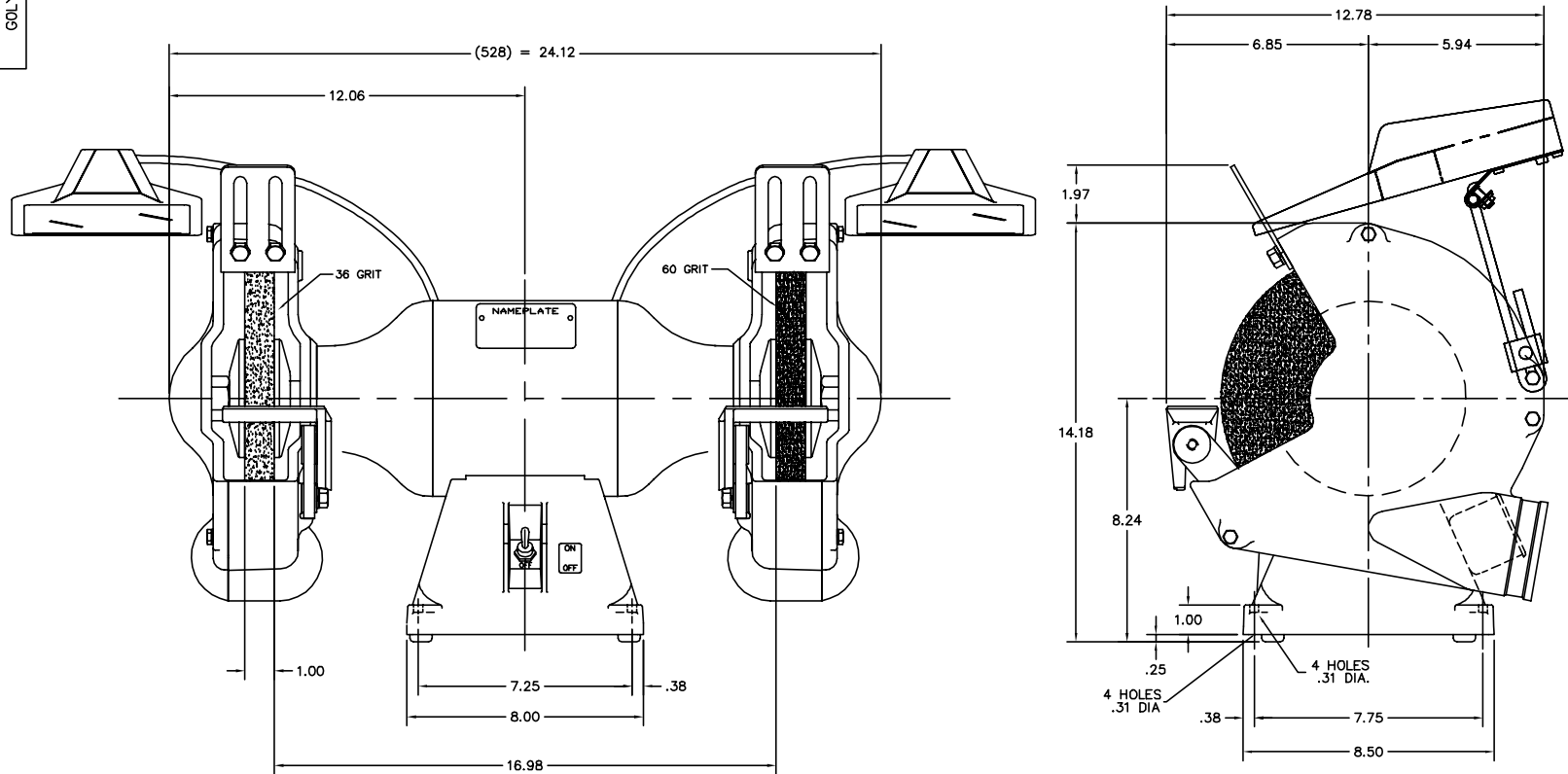

GOLY0237

CUSTOMER IS RESPONSIBLE FOR DETERMINING THAT MOTOR PERFORMANCE IS SUITABLE IN THE APPLICATION.

REV. DESC: REMOVE FELT WASHER (HA1025A03)		
REV. LTR: G	VERSION: 01	TDR: 000000357606
FILE: \AAA\00035\654	REVISED: 08:21:15 10/06/2005	BY: ENJASFO
MTL: -		

BALDOR ELECTRIC Co.

STD 10" GRINDER (528C) W/EYESHIELD

