

# **BALDOR**® • *RELIANCE*

## **Product Information Packet**

# **CESWDM3546T**

**1HP, 1760RPM, 3PH, 60HZ, 143TC, 3524M, TENV, F1**

Part Detail							
Revision:	G	Status:	PRD/A	Change #:		Proprietary:	No
Type:	AC	Elec. Spec:	35WGM302	CD Diagram:	CD0005	Mfg Plant:	
Mech. Spec:	35SS621	Layout:	35LYSS621	Poles:	04	Created Date:	02-13-2015
Base:	RG	Eff. Date:	03-30-2017	Leads:	9#18		

Specs			
Catalog Number:	CESWDM3546T	Insulation Class:	F
Enclosure:	TENV	Inverter Code:	Inverter Ready
Frame:	143TC	KVA Code:	N
Frame Material:	Stainless Steel	Lifting Lugs:	No Lifting Lugs
Output @ Frequency:	1.000 HP @ 60 HZ	Locked Bearing Indicator:	Locked Bearing
Synchronous Speed @ Frequency:	1800 RPM @ 60 HZ	Motor Lead Quantity/Wire Size:	9 @ 18 AWG
Voltage @ Frequency:	460.0 V @ 60 HZ	Motor Lead Exit:	Ko Box
	230.0 V @ 60 HZ	Motor Lead Termination:	Flying Leads
XP Class and Group:	None	Motor Type:	3524M
XP Division:	Not Applicable	Mounting Arrangement:	F1
Agency Approvals:	UR	Power Factor:	72
	CSA EEV	Product Family:	Wash Down Paint Free
	CSA	Pulley End Bearing Type:	Sealed Bearing
Auxillary Box:	No Auxillary Box	Pulley Face Code:	C-Face
Auxillary Box Lead Termination:	None	Pulley Shaft Indicator:	Standard
Base Indicator:	Rigid	Rodent Screen:	None
Bearing Grease Type:	Polyrex EM (-20F +300F)	RoHS Status:	ROHS COMPLIANT
Blower:	None	Shaft Extension Location:	Pulley End

<b>Current @ Voltage:</b>	1.500 A @ 460.0 V	<b>Shaft Ground Indicator:</b>	No Shaft Grounding
	3.000 A @ 230.0 V	<b>Shaft Rotation:</b>	Reversible
	3.100 A @ 208.0 V	<b>Shaft Slinger Indicator:</b>	No Slinger
<b>Design Code:</b>	B	<b>Speed Code:</b>	Single Speed
<b>Drip Cover:</b>	No Drip Cover	<b>Motor Standards:</b>	NEMA
<b>Duty Rating:</b>	CONT	<b>Starting Method:</b>	Direct on line
<b>Electrically Isolated Bearing:</b>	Not Electrically Isolated	<b>Thermal Device - Bearing:</b>	None
<b>Feedback Device:</b>	NO FEEDBACK	<b>Thermal Device - Winding:</b>	None
<b>Front Face Code:</b>	Standard	<b>Vibration Sensor Indicator:</b>	No Vibration Sensor
<b>Front Shaft Indicator:</b>	None	<b>Winding Thermal 1:</b>	None
<b>Heater Indicator:</b>	No Heater	<b>Winding Thermal 2:</b>	None

Nameplate NP1669L										
CAT.NO.	CESWDM3546T									
SPEC.	35SS621M302G1									
HP	1									
VOLTS	230/460									
AMP	3/1.5									
RPM	1760									
FRAME	143TC				HZ	60			PH	3
SER.F.	1.15		CODE	N	DES	B		CLASS	F	
NEMA-NOM-EFF	87.5		PF	72						
RATING	40C AMB-CONT									
CC	010A				USABLE AT 208V			3.1		
DE	6205				ODE	6203				
ENCL	TENV		SN							
BLANK										

Parts List		
Part Number	Description	Quantity
SA294056	SA 35SS621M302G1	1.000 EA
RA280140	RA 35SS621M302G1	1.000 EA
NS2512A01	INSULATOR, CONDUIT BOX X	1.000 EA
35CB5001A21	CONDUIT BOX KIT, FOR SUPER II WASHDOWN	1.000 EA
11XW1032G06	10-32 X .38, TAPTITE II, HEX WSHR SLTD U	1.000 EA
35EP3100M72MU	SPL FR EP-ENCL-203 BRG-DIE CAST ALUM(BAL	1.000 EA
HW4500A33	1/8 NPT STAINLESS,HOLO-KROME #13002,PRES	3.000 EA
HW5100A03	WAVY WASHER (W1543-017)	1.000 EA
35PE3300A75MU	PU E.P., CAST-FACE MTD-56C-205 BRG(BALL	1.000 EA
HW4500A33	1/8 NPT STAINLESS,HOLO-KROME #13002,PRES	3.000 EA
HW4606A02	JM CLIPPER/SEAL (LWE-0938-1624-AL23)	1.000 EA
12XN1032S20	10-32 X 1-1/4 HEX M.S. , STAINLESS STEEL	2.000 EA
HA1049A01	DUBO LOK WASHER SIZE 10 (NYLON LOCK SEAL	2.000 EA
HA1049A01	DUBO LOK WASHER SIZE 10 (NYLON LOCK SEAL	4.000 EA
HW2502D13	SS KEY, 3/16 SQ X 1.375	1.000 EA
HA7000A01	KEY RETAINER 7/8" DIA SHAFT	1.000 EA
MJ5001A02	732 CL SEALANT 3 OZ DIXIE BEARING 289100	0.001 EA
85XU0407S04	4X1/4 U DRIVE PIN STAINLESS	2.000 EA
LB1164	LABEL,WARNING AND DRAIN	1.000 EA
HA5027A04	HA4054 T-DRAIN X2 BAGGED	1.000 EA
MJ1000A02	GREASE, POLYREX EM EXXON (USe 4824-15A)	0.050 LB
HA3100S24	THRUBOLT 8.625 LENGTH 1.250 TH LENGTH SS	4.000 EA
LC0005	CONN.DIA.,TY M,9-LD,DUAL VOLT,REVERSING	1.000 EA
NP1669L	SS WD SUPER-E UL CSA-EEV PREM REV MTG	1.000 EA

<b>Parts List (continued)</b>		
<b>Part Number</b>	<b>Description</b>	<b>Quantity</b>
35PA1066	PKG GRP, PRINT PK1008A06	1.000 EA
MN416A01	TAG-INSTAL-MAINT no wire (1100/bx) 11/14	1.000 EA

No performance data has been  
assigned to this product.

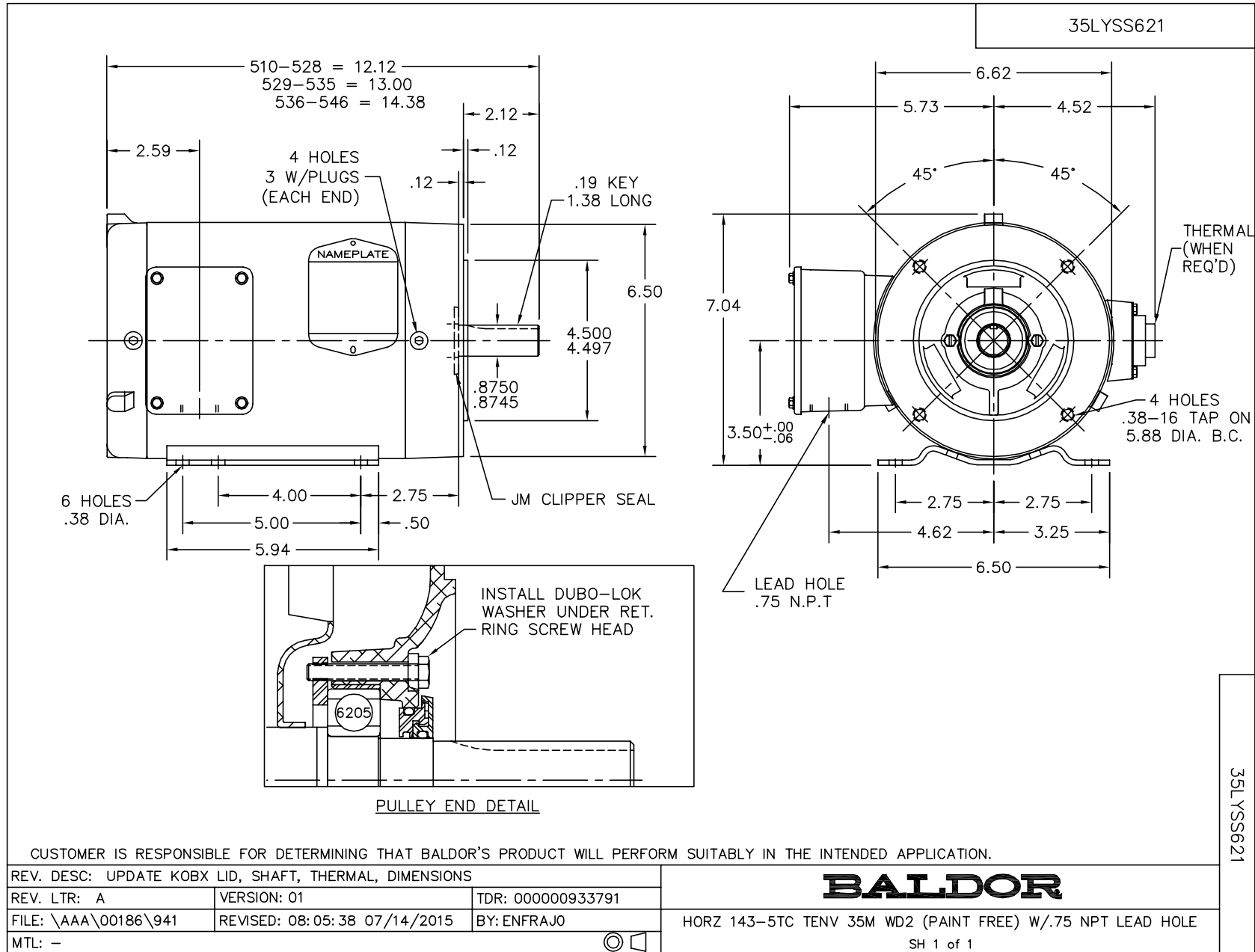



CD0005



LOW VOLTAGE  
(2Y)

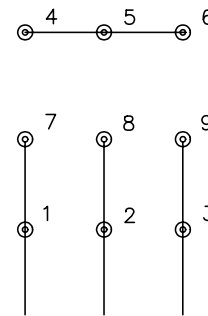

LINE

HIGH VOLTAGE  
(1Y)

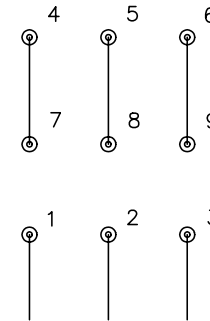

LINE

NOTES:

1. INTERCHANGE ANY TWO LINE LEADS TO REVERSE ROTATION.
2. OPTIONAL THERMOSTATS ARE PROVIDED WHEN SPECIFIED.
3. ACTUAL NUMBER OF INTERNAL PARALLEL CIRCUITS MAY BE A MULTIPLE OF THOSE SHOWN ABOVE.
4. LEAD COLORS ARE OPTIONAL. LEADS MUST ALWAYS BE NUMBERED AS SHOWN.

REV. DESC: REVISE TO SHOW OPTIONAL COLORS			
REV. LTR: E	BY: JLP	REVISED: 01/19/99 10:15	TDR: 0171435
9000D		FILE: AAA00005140	MDL: -
		MTL: -	

**BALDOR ELECTRIC Co.**

3PH, DV, 9 LEADS

CD0005